



Perfect Appearance Excellent Performance

精 于 静 精 于 动

1700MM F4U CORSAIR

OPERATING MANUAL



<http://www.facebook.com/FMSmodel>



www.fmsmodel.com

Please visit both our Facebook fanpage and our homepage for updated product information

WARNING

 **WARNING:** Read the ENTIRE instruction manual to become familiar with the features of the product before operating. Failure to operate the product correctly can result in damage to the product, personal property and cause serious injury.

This is a sophisticated hobby product and NOT a toy. It must be operated with caution and common sense and enquires some basic mechanical ability. Failure to operate this Product in a safe and responsible manner could result in injury or damage to the product or other property. This product is not intended for use by children without direct adult supervision.

This manual contains instructions for safety, operation and maintenance. It is essential to read and follow all the instructions and warnings in manual, prior to assembly, setup or use, in order to operate correctly and avoid damage or serious injury.

Safety Precautions and Warnings

As the user of this product, you are solely responsible for operating in a manner that does not endanger yourself and others or result in damage to the product or the property of others. This model is controlled by a radio signal subject to interference from many sources outside your control. This interference can cause momentary loss of control so it is advisable to always keep a safe distance in all directions around your model, as this margin will help avoid collisions or injury.

Age Recommendation: Not for children under 14 years. This is not a toy.

- Never operate your model with low transmitter batteries.
- Always operate your model in an open area away from cars, traffic or people.
- Avoid operating your model in the street where injury or damage can occur.
- Never operate the model in the street or in populated areas for any reason.
- Carefully follow the directions and warnings for this and any optional support equipment (chargers, rechargeable battery packs, etc.) you use.
- Keep all chemicals, small parts and anything electrical out of the reach of children.
- Moisture causes damage to electronics. Avoid water exposure to all equipment not specifically designed and protected for this purpose.
- Never lick or place any portion of your model in your mouth as it could cause serious injury or even death.

FMS Kindly Reminder



Thank you for your great attention and support to our company.

If there is any problem regarding the plane, or any suggestion on our products, such as manual, package, color scheme, even structure, please feel free to contact us at info@fmsmodel.com

Installing the control horn

1. The plastic control surface horns for the rudder and elevator are stapled to the bags containing the rudder and elevator, do not to accidentally discard them.



2. The top side of the elevator attached two plastic washer.



3. Install the elevator control surface horns with the screws provided in the small plastic bag on the bottom of the elevator surface. Make sure the control surface horn is facing the proper direction before installing for the most deflection.



4. Install the control horn of the rudder on the left side the same with the elevator.



5. Always make sure that the screws are seated into the back plates of the control horns. It is very important that these are tight during flight.



Installing the control horn

6. Now attach the aileron surface control horn onto the bottom of the main-wing half.



7. Next attach the flap control surface horn, you will need to hold the back plate in place when you use the screwdriver to tighten the screws.



Installing the linkage rod

1. Put the Z bend end of the linkage in the desired surface control horn hole (For the aileron and flap). It will fit tightly but will allow the linkage to move slightly within the hole to avoid binding up.



2. Snap the plastic clevis end of the linkage into the surface control horn.



3. The provided piece of fuel tubing keeps the clevis closed during flight. Do all the linkages the same way.



Install the stabilizer

1. Attach the horizontal stabilizer first.
Mount the stabilizer into the pre-notched aft section of the fuselage with the top side face up. Use two screws to secure it.
All of the measurements of the screws we have described in the manual has been tagged to the dedicated spare parts bag.
Please refer to the measurements on the manual and the spare parts bag for the convenient usage.



2. Make sure the horizontal stabilizer align with the fuselage.
(PM3.0*30 2PCS)

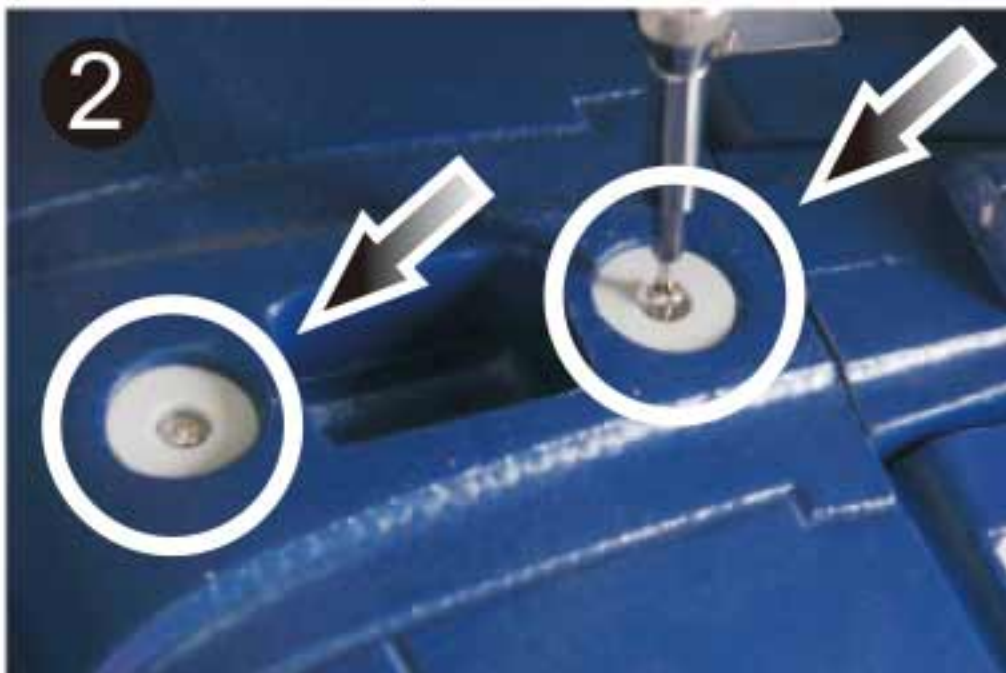

3. Now the vertical stabilizer is ready to be mounted. Gently push the stabilizer down until it is fully seated with no gaps between it and the fuselage, it fits perfectly when properly pushed down.



4. Secure the rudder with the in stored screws, we need to deploy the rear landing gear hatch door the first to access the combine nuts on the stabilizer.



5. Tighten the rear screw by insert the screw into the plastic washer first.
(PM3.0*30 1PC)



6. Tighten the front side two screws by insert the screws through the pre-notched hole in the rear landing gear base first.
(PM3.0*40 2PCS)

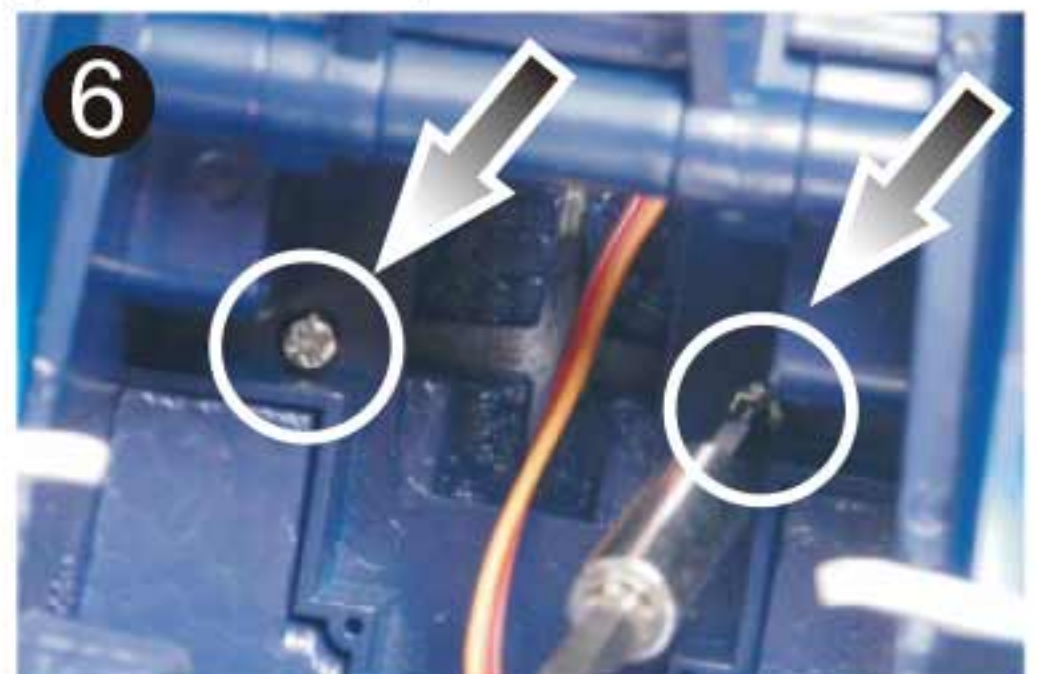

Mount the main wing

1. The configuration of the two wing panel connection tubes.
The longer one on the leading edge side of the main wing, the shorter one on the trailing edge side.

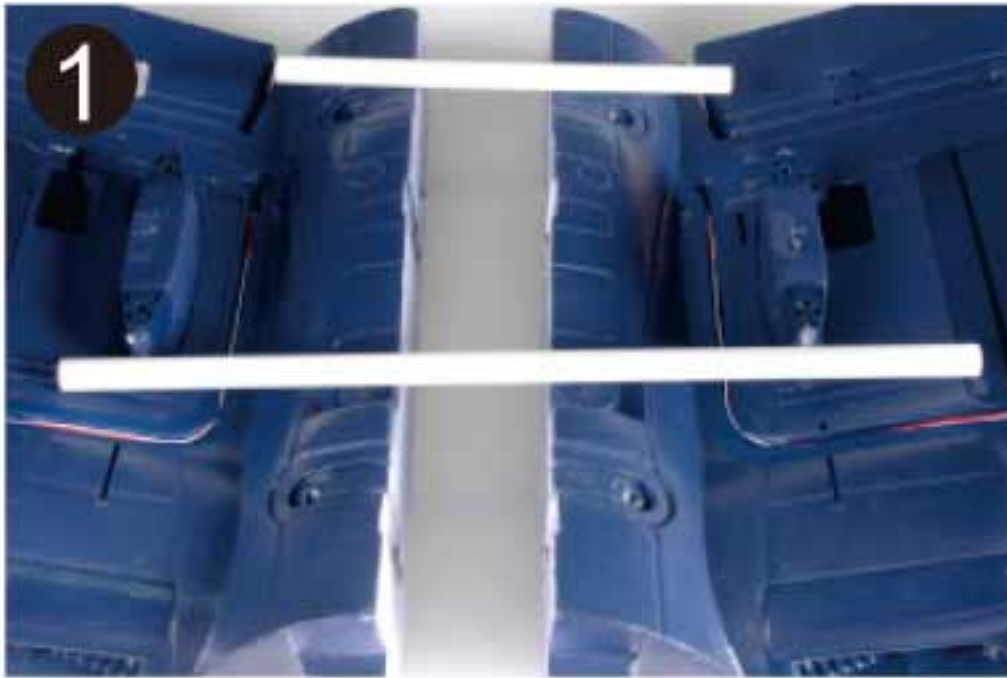

2. Locate the main wing tube, slide the tube in one wing panel. It should slide in easily, so do not force the further than it will slide. This will push the wing tube into the foam in the wing, and possibly prevent it from inserting fully into the opposite wing panel.



3. Slide the remaining wing panel into position. The panels will fit tightly together.



4. Use a small amount of glue to secure the front wing bolt panel, rear wing bolt panel. It will help holding the plate more tighten.

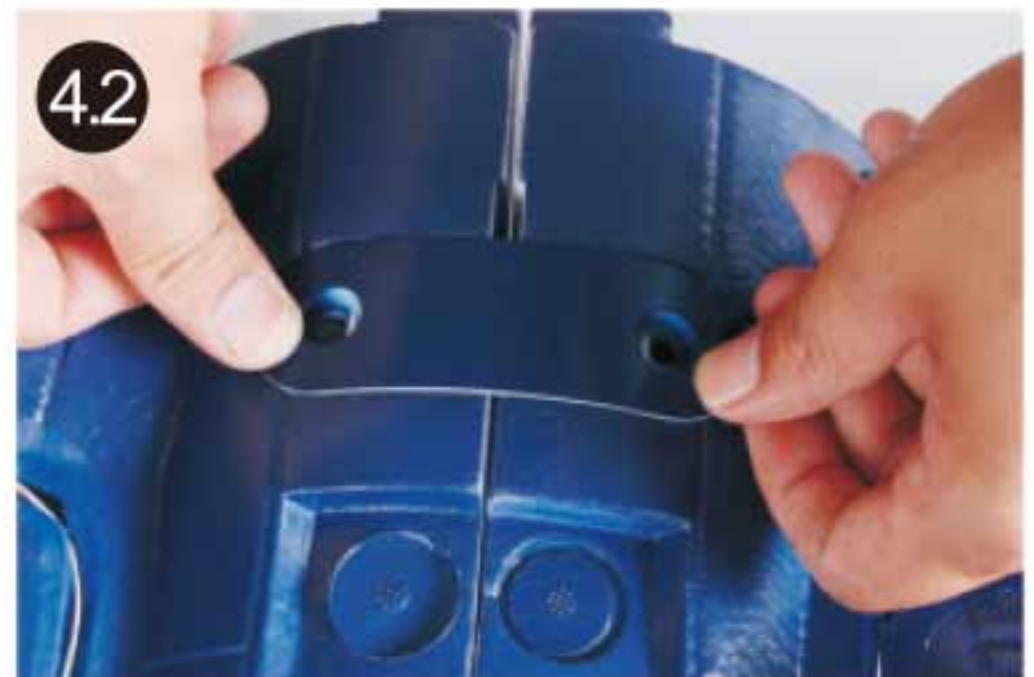

5. Position the wing so the foam block in the forward of the wing panel fit into the slot in the front of the fuselage.



step4-5

Mount the main wing

6. Guide the leads from the **Part 1** Guiding the multiple connector leads (For the aileron and flap servos and retracts) through the hole in the bottom of the fuselage.



7. Hold the rear end of the main wing panel and push it into place slightly.



8. Use a screwdriver to tighten the four screws that secure the wing. Two screws are used in the rear wing bolt plate and two in the front wing plate. (M6*80 2PCS M6*88 2PCS)

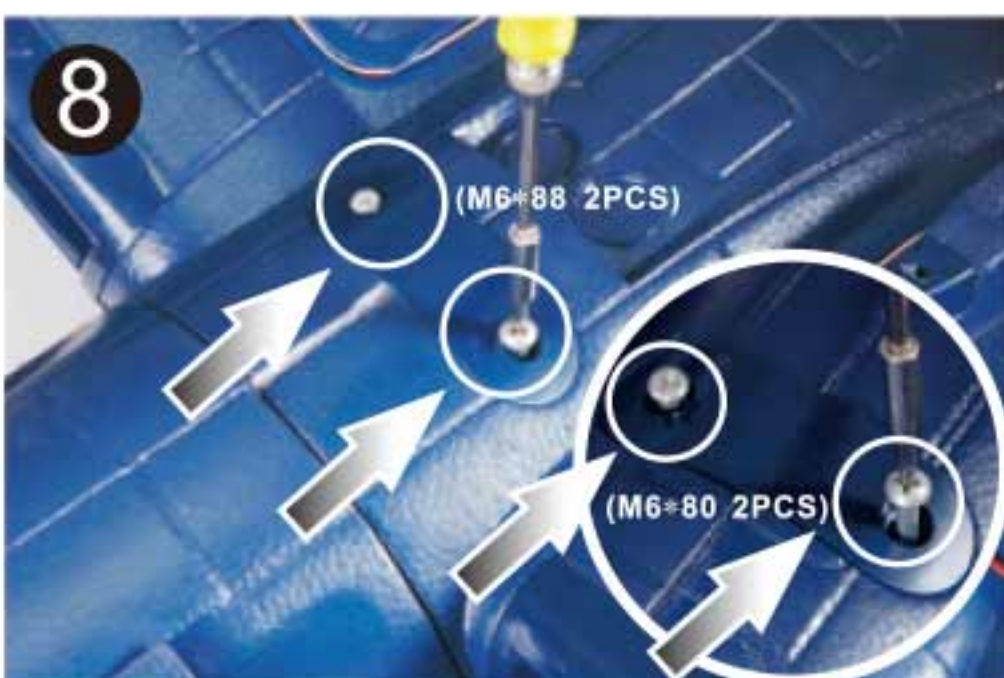

Load the oil tank and rocket

1. Slap the oil tank on the pre installed tank rack, make sure the bigger head of the tank toward the nose side of the plane. There are no different between this two tank.



2. Load the rockets, take the pre installed wing shape foam filler out by thread out the screw, please note there are no slots in the filler for the rockets installation (It can be used for no rockets load flying.)

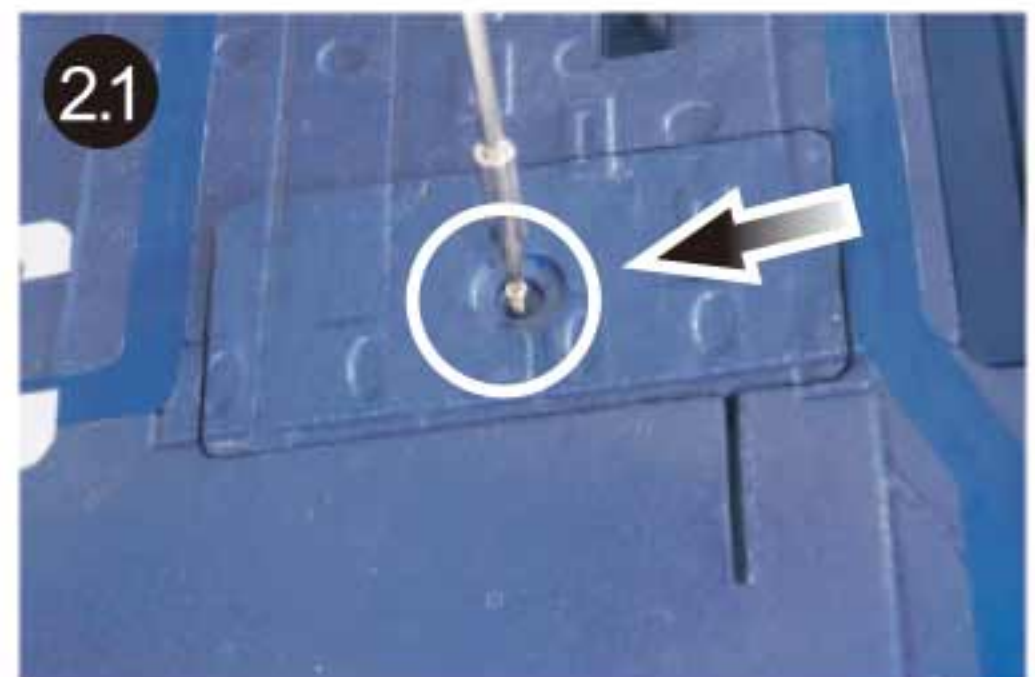

Load the oil tank and rocket

3. Take out the in stored wing shape rockets mount plate with the rocket mount slot from spare part bag, and try it for the rightly installation.
Please note the panel line on the plate align with the line on the wing panel. If not, please to fit it to the other wing panel.



4. Where the finger tip point is the panel line.



5. Remove the plate and apply a thin coat of glue on the rocket where the plate and rocket fit together and fit it to plate with the panel line toward the tail fin of the rocket.



6. Verify the completed rockets installation.



7. Fit the rocket set into place by put the wing tip side into place first, then squeeze the other end into place, please note there is no glue applying in this step.
Always follow the steps in manual will provide an excellent model building.



8. Secure the backplate with the uninstalled screws.
The installation on both set of rockets are the same.

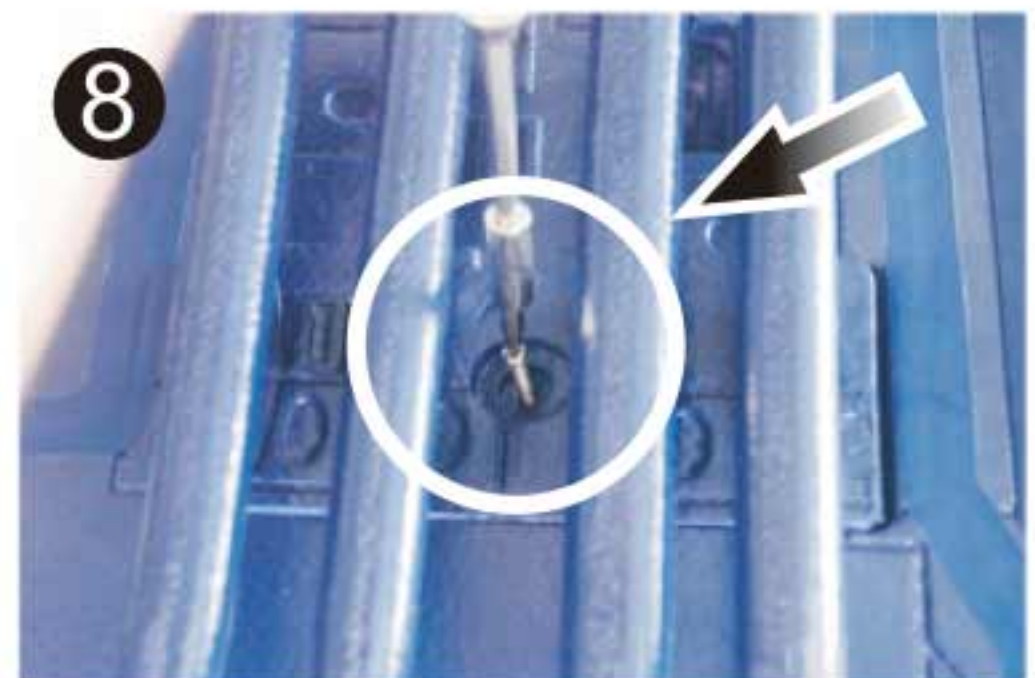

Installing the propeller

1. Take the propeller back plate out, the one with a hex hole in center. Place the in stored nuts into the peripheral pre-notched nuts hole on back of the plate.



2. Then fit the blade in place with the letter side face up, use the shorter screw in stored with the spinner to secure the blade in the blade tip side screw hole.



3. Make sure holding the nut into place when we tighten the screw. It will help a lot when you doing the screw installation and save you extra time.



4. After the installation of the blade make sure there is no gap between the back propeller holder plate and the propeller root, if not, you will have to check to make sure there is nothing come to obstruct the fully installation of the blade, and then tighten the screw properly again. Do the rest 3 pieces blade the same.



5. Place the front propeller holder plate into place as show.



Installing the propeller

6. Then implement the nuts into the inside track of the back plate.
Tighten the screws on the front plate.



7. After the four screws' tightening complete, make sure there is no gap between this two propeller holder plate.



8. Verify the status of the propeller installation completed.



9. Keyed the propeller assembly to the motor shaft, make sure fit the assembly into the hex stage on the shaft, it will help to hold the assembly in fixed position when the engine contact.

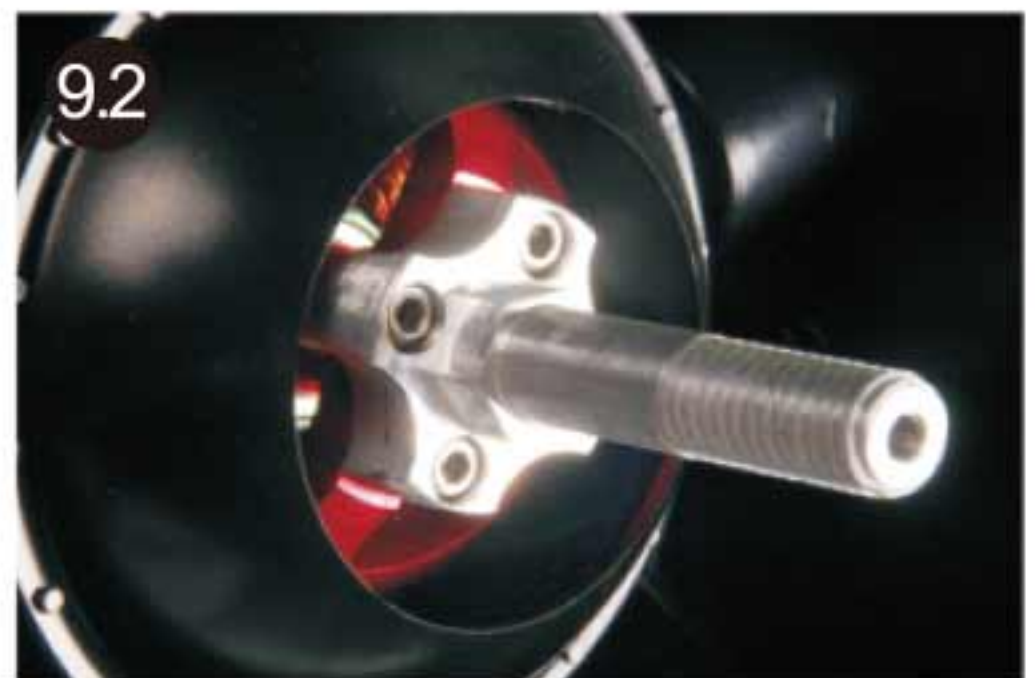

Installing the propeller

10. Take the washer and thread it to the motor shaft, it will help to prevent the propeller holder from the nut scrape.



11. Secure the propeller by tighten the nut use the wrench, do not over tighten, but make sure it's tight enough.



12. Install the spinner and tighten by hand firmly.



Install the antenna and speed head

1. Attach the scale three pieces antenna as the picture show.
Make sure the antenna to be installed in the right direction.



2. Apply glue on the antenna where it fit with the fuselage together.
Do the rest antenna installation the same.



3. The airspeed indicator or "pitot" tube goes on the end of the right or starboard wing tip.



4. Make sure the indicator been properly fitted into position.



Wire connecting

1. Remove the canopy hatch from the fuselage by holding the hatch band at the front. The canopy attaches to the fuselage using a magnet at the front and foam block at the rear.



Multiple connector Part 1



2. Plug the leads from the aileron flap and retract system into the right port of the Multiple connector. Note the signal wire on the channel label side. Every lead has its own channel label mark. This step has been factory completed. Perform the step when change the electronic part or do some main wing repair.

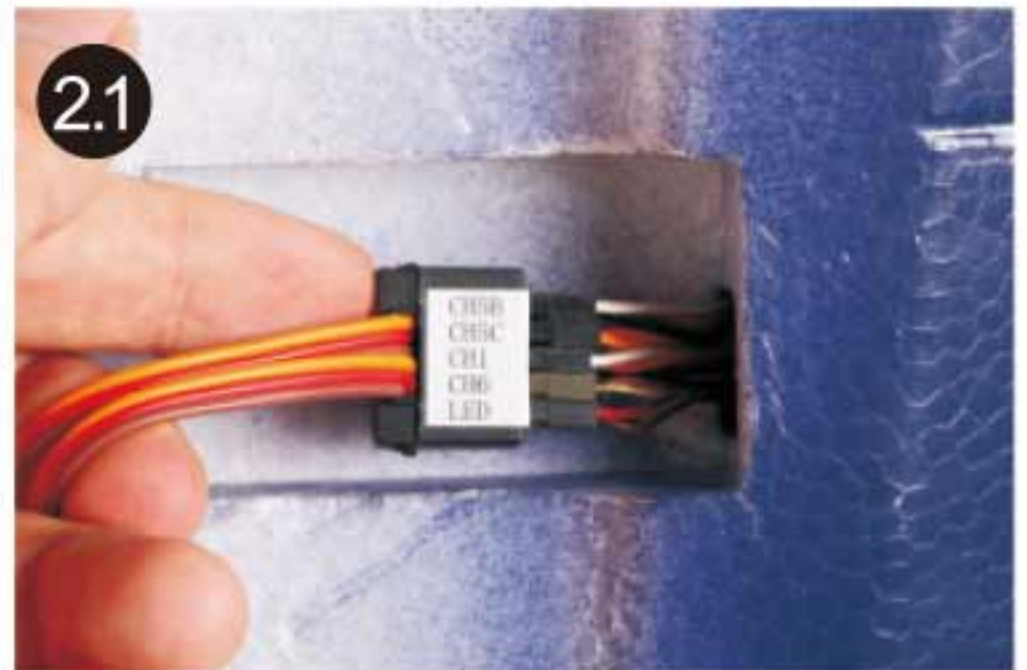

Multiple connector Part 2



3. Plug the **Part 1** to the **Part 2** properly as the picture show.



Wire connecting

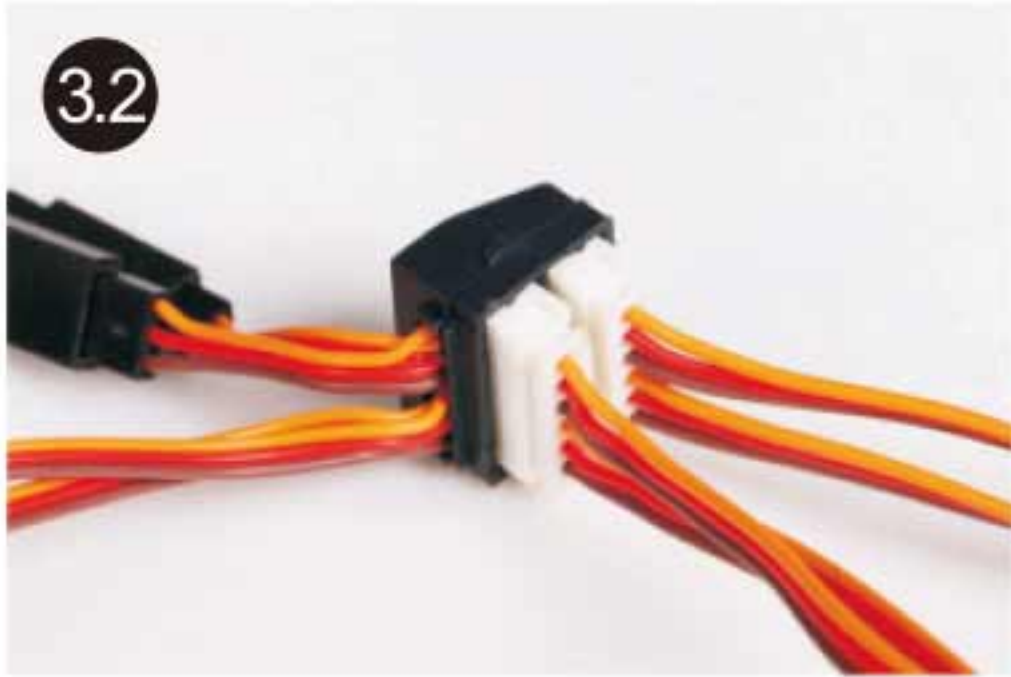

4. Socket **Ch5 B** for rear retract landing gear servo. Socket **Ch5 C** for rear landing gear hatch cover. The leads of this two servo come from the rear part of the fuselage, please be care to plug the leads rightly into this two sockets.

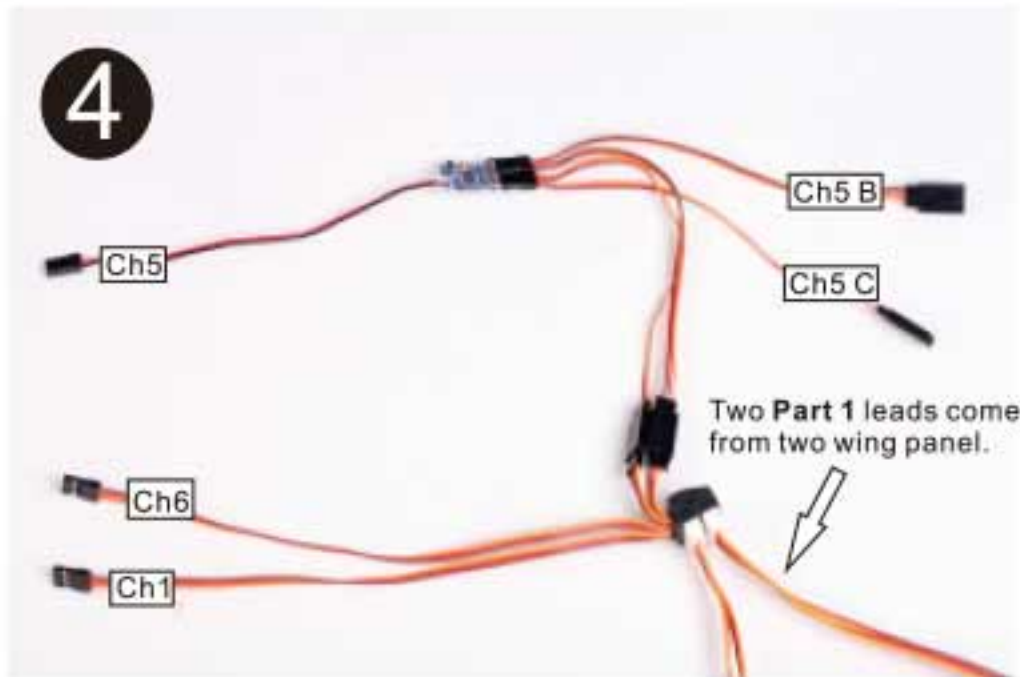

5. Diagram for the sequencer connection.

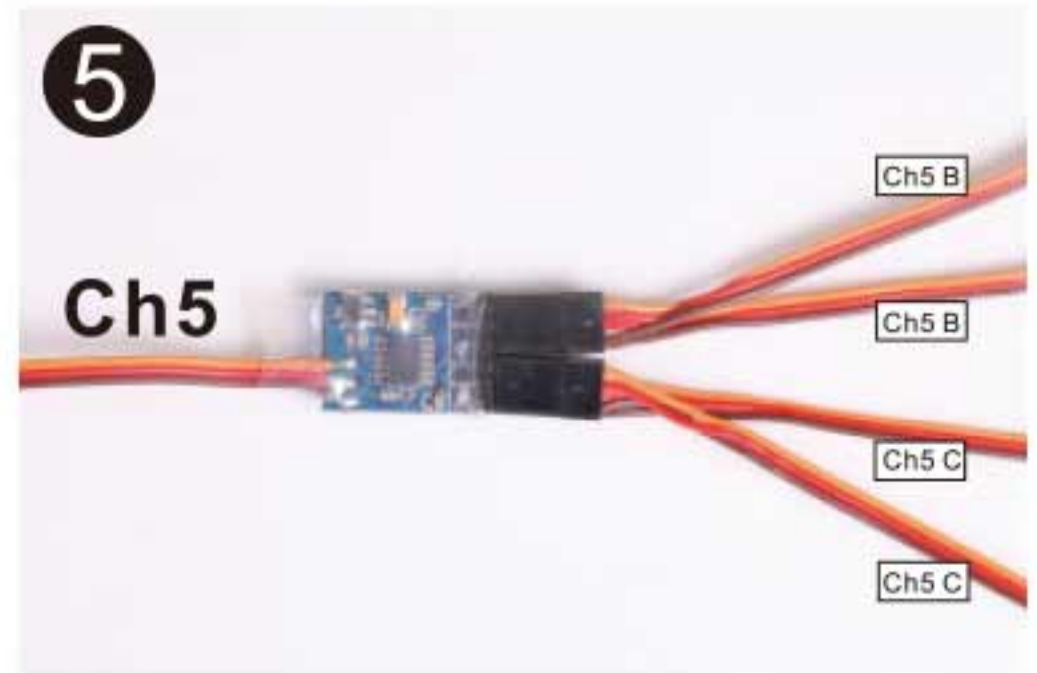

6. Diagram for the receiver connection.

		Receiver
Aileron	Ch1	Channel-1
Elevator	Ch2	Channel-2
Throttle	Ch3	Channel-3
Rudder	Ch4	Channel-4
Landing Gear	Ch5	Channel-5
Flap	Ch6	Channel-6

Wire connecting

7. Place the receiver under the servo board. The minimum distance between the BEC and receiver is 5mm.

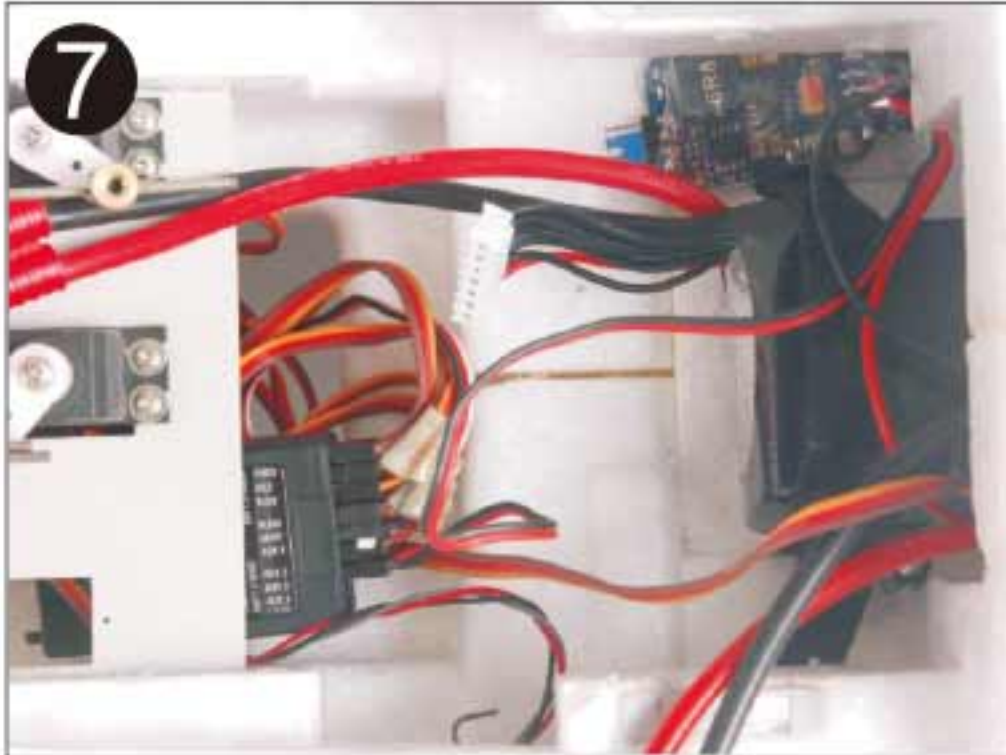

8. After the connection of the servo tuck the wire mess under the servo board for the neatly looking of the canopy hatch and avoiding the interfere between the servo and the mess.



Install the battery

1. Attach the velcro strap to the battery, install the battery with the velcro strap side face down and secure it with the hook and loop strap. You can adjust the battery position by move the battery back and forth for the right CG position.



Neutral position of the control surface

1. The neutral position of the control surface. Make sure all the control surface in the neutral position. The aileron, the trailing edge of the aileron align with trailing edge of the wing tip.

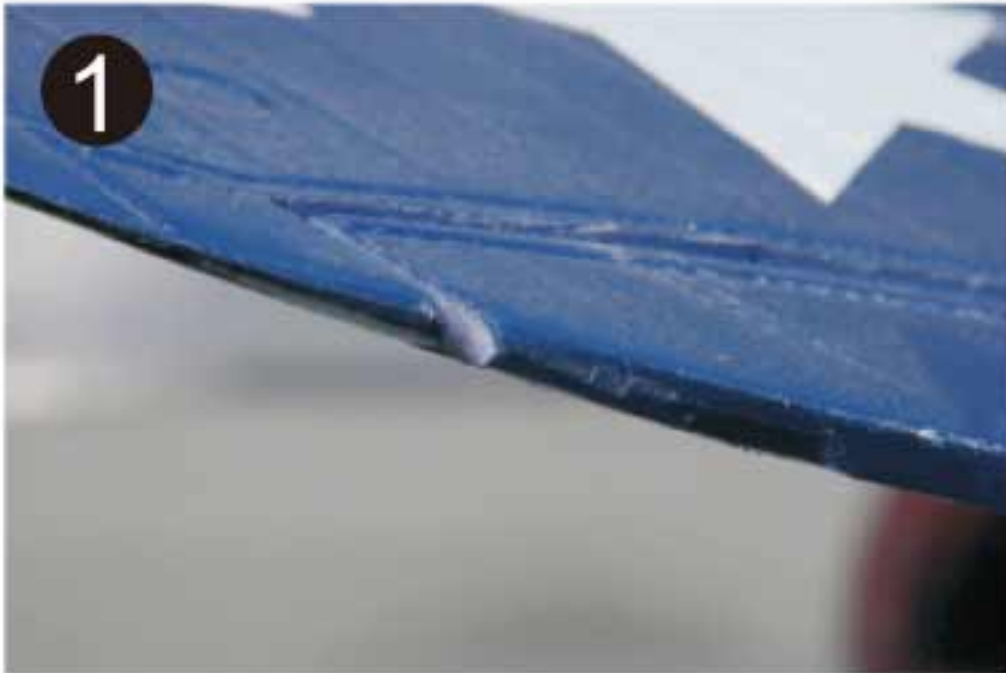

2. The outer flap, the trailing edge of the outer flap align with trailing edge of the aileron.

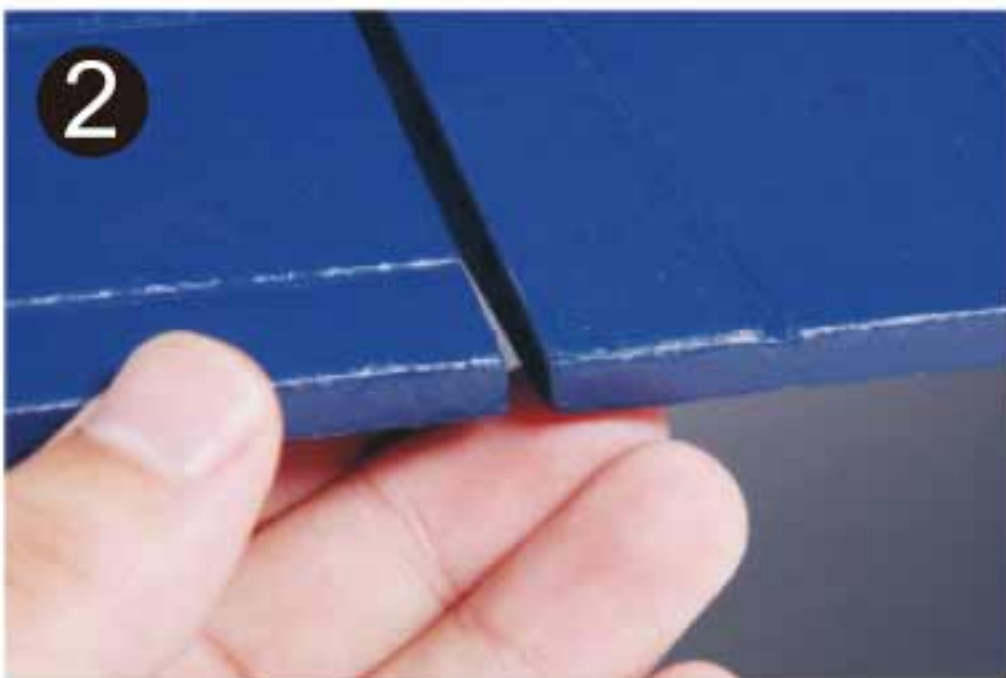

3. The inner flap, the trailing edge of the inner flap align with trailing edge of the outer flap.

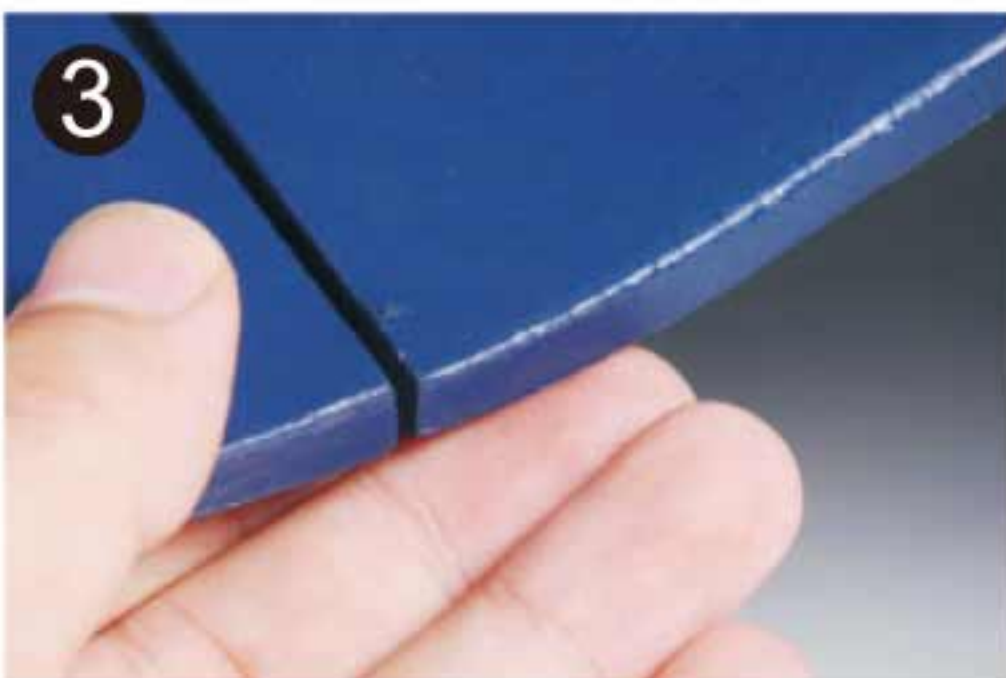

4. The rudder, the trailing edge of the rudder align with trailing edge of the rudder root.



5. The elevator, the trailing edge of the elevator align with trailing edge of the elevator root.



Specification Of 6A UBEC:

1. Switch Mode
2. Output: 5.0V/6A , 5.5V/6A or 6.0V/6A switchable (Changeable with a blue jumper)
3. Input: 6V-25V (2-6S Lipo, 5-18S NiMH/NiCd)
4. Output Current: Continuous Current 6A, Burst Current 10A
5. Size: 45.0mm*23.0mm*10.0mm (Length*Width*Height)
6. Weight: 18.0g

Note: We recommend use the jumper cap to connect the two middle pins in four for your safty flying.

Features :

1. Adopting the USA CPU and decreasing the electromagnetic interference, to be sure that receiver works well.
2. The working status of UBEC is shown by an indicator (LED). When UBEC works, the blue LED lights.
3. Battery polarity reversal protection (If the connection is wrong, the UBEC can not work.)

How to Use the UBEC, please carefully look at the connections as follows :

1. Connecting UBEC with ESC OPTO, you just parallely connect the input connector of UBEC with the battery pack, and plug the output connector of the UBEC into one of spare channels of the receiver.
2. Using ESC SBEC, you must remove the red wire of the signal wires of ESC SBEC to receiver before connecting with the UBEC. (the connection with ESC SBEC is same as connection with the ESC OPTO)

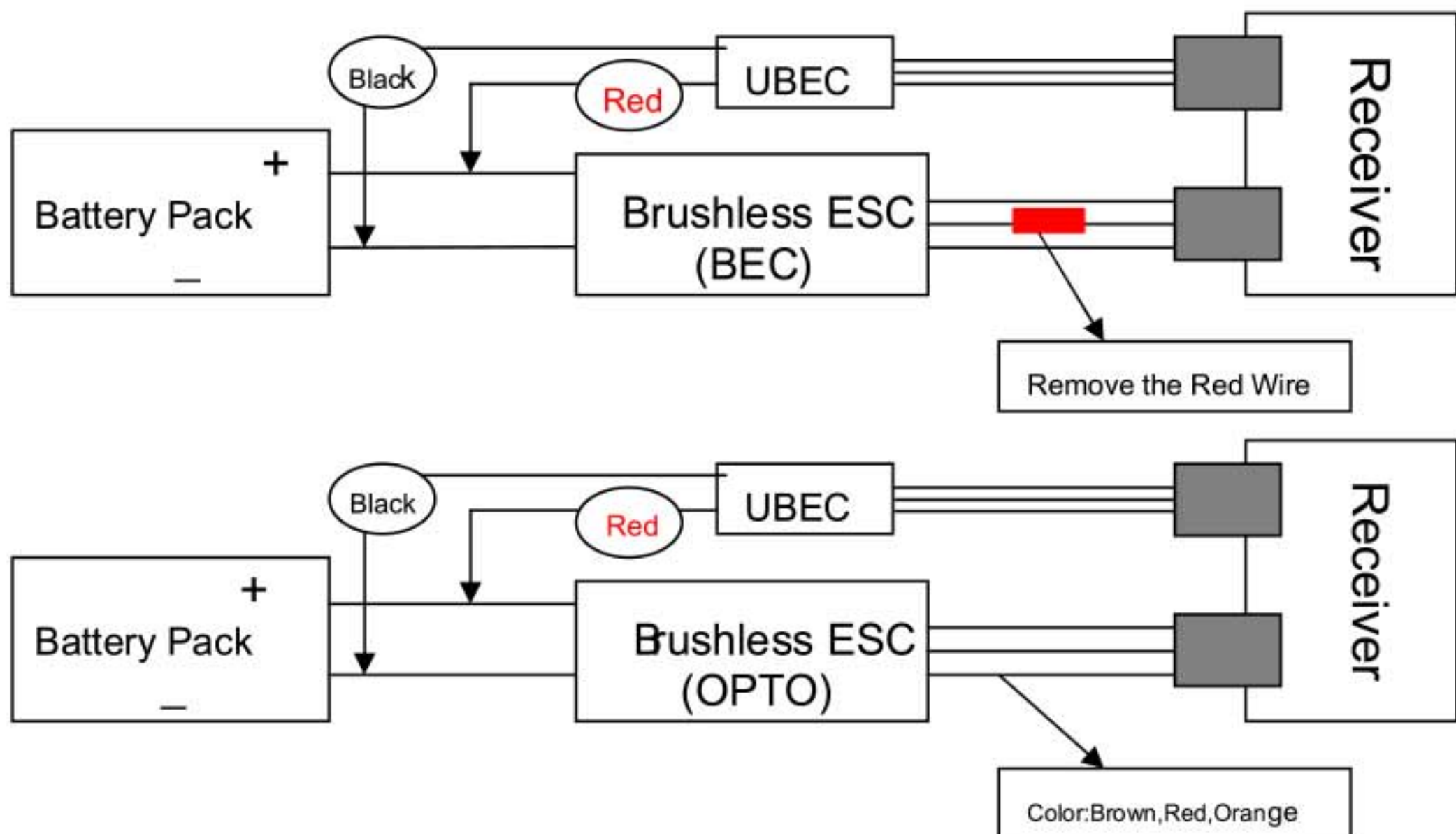

Note: Because of the weather and ground, please connect the UBEC at least in a distance 5cm far away from the receiver to avoid the electromagnetic interference.

Main specification

Specification

Wingspan	: 1700mm /66.9in
Length	: 1380mm /54.3 in
Weight	: 4700g /165.8 oz
CG Position	: 120mm
Battery	: 22.2V 3300mAh Li-Po Battery
ESC	: 85A
Motor	: 5060-KV300
Wing Area	: 54.7dm ²
Wing Load	: 85.9g/dm ²
RC System	: 6 Channel, 13 Servos And 1 Brushless ESC

Center Of Gravity(C.G.)



Center of Gravity

When balance your model, adjust the motor battery as necessary so the model is level or slightly nose down.

This the correct balance point for your model.

After the first flights, The **CG** position can be adjusted for your personal preference.

1. The recommended Center of Gravity(**CG**) location for your model is (120mm/4.7in) back from the leading edge of the top main wing as shown with the battery pack installed. Mark the location of the **CG** on top of the wing.
2. When balancing your model, support the plane inverted at the marks made on the top of the main wing with your fingers or a commercially available balancing stand. This is the correct balance point for your model, Make sure the model is assembled and ready for flight before balancing.

Note: Always balance the plane with the retracts down.

Control throw setting

1. Turn on the transmitter and receiver of your model.
check the movement of the rudder using the transmitter.
When the stick is moved right, the rudder should also move right. Reverse the direction of the servo at the transmitter if necessary.
2. Check the movement of the elevator with the radio system.
Moving the elevator stick toward the bottom of the transmitter makes the airplane elevator move up.
3. Check the movement of the ailerons with the radio system, moving the aileron stick right makes the right aileron move up and left aileron move down.
4. Use a ruler to adjust the throw of the elevator, aileron and rudder.
Adjust the position of the pushrod at the control horn and the transmitter to achieve the following measurements when moving the sticks to the end point.

Note: Always disassemble the propeller set when binding the transmitter and testing the control surface.

Main specification and spare parts

The suggested throws for the FMS F4U are as follows:

	High rate	Low rate
Elevator -	40mm/1.6in up and down	24mm/0.9in up and down
Rudder -	25mm/0.98in left and right	21mm/0.8in left and right
Ailerons -	28mm/1.1in up and down	17mm/0.7in up and down
Flap -	Mid 22mm/0.9in Full 45mm/1.8in	

Spare Parts List for Blue Scheme

Item#	Description
SI101-Blue	Fuselage
SI102-Blue	Main Wing Set (Right and left side 2PCS)
SI103-Blue	Rudder
SI104-Blue	Elevator
SI105-Blue	Canopy (One foam canopy)
SI106-Blue	Canopy (One plastic canopy)
SI107-Blue	Oil Tank (2PCS)
SI108-Blue	Rockets (8PCS)
SI201-Blue	Cowl
SI202-Blue	Antenna Set (3PCS)
SI203-Blue	Air Speed Indicator
SI204-Blue	Main Wing Bolt Plate (2PCS)
SI205-Blue	Rear Landing Gear Hatch Cover
SI206-Blue	Front Landing Gear Hatch Cover
SI-207	Propeller (4PCS)
SI208-Blue	Rear Landing Gear Set (Rear landing gear assembly with a 17g teering servo pre installed)
SI 209-Blue	E-retract System (For front landing gear with two E-retract and main landing gear set) (2PCS)
SI-210	E-retract (For Main Landing Gear) (2PCS)
SI211-Blue	Front Landing Gear Strut Set (2PCS)
SI-301	Brushless Motor(5060-KV300)
SI-302	ESC (85A with 6A UBEC)
SI-303	9g Servo
SI-304	17g Servo
SI-305	25g Metal Servo
SI-306	Motor Board
SI-307	Motor Shaft
SI-308	Linkage Rod
SI-309	Motor Mount
SI-310	Spinner
SI-311	Screws Set
SI312-Blue	Stickers (A set of stickers)
SI-313	Multiple Connector Part 1 (From the wing panels)
SI-314	Multiple Connector Part 2 (For plugging to receiver)

spare parts

Spare Parts List for Grey Scheme

Item#	Description
SI101-Grey	Fuselage
SI102-Grey	Main Wing Set (Right and left side 2PCS)
SI103-Grey	Rudder
SI104-Grey	Elevator
SI105-Grey	Canopy (One foam canopy)
SI106-Grey	Canopy (One plastic canopy)
SI107-Grey	Oil Tank (2PCS)
SI108 -Grey	Rockets (8PCS)
SI201-Grey	Cowl
SI202-Grey	Antenna Set (3PCS)
SI203-Grey	Air Speed Indicator
SI204-Grey	Main Wing Bolt Plate (2PCS)
SI205-Grey	Rear Landing Gear Hatch Cover
SI206-Grey	Front Landing Gear Hatch Cover
SI208-Grey	Rear Landing Gear Set (Rear landing gear assembly with a 17g steering servo pre installed)
SI209-Grey	E-retract System (For front landing gear with two E-retract and main landing gear set) (2PCS)
SI211-Grey	Front Landing Gear Strut Set(2PCS)
SI312-Grey	Stickers (A set of stickers)

- Note:** 1. All spare parts without decals.
2. The Item# without color marking could be applied universally for both color scheme.

Spare Parts List for Blue Scheme



SI101-Blue



SI102-Blue



SI103-Blue



SI104-Blue



SI105-Blue



SI106-Blue



SI107-Blue



SI108-Blue



SI201-Blue

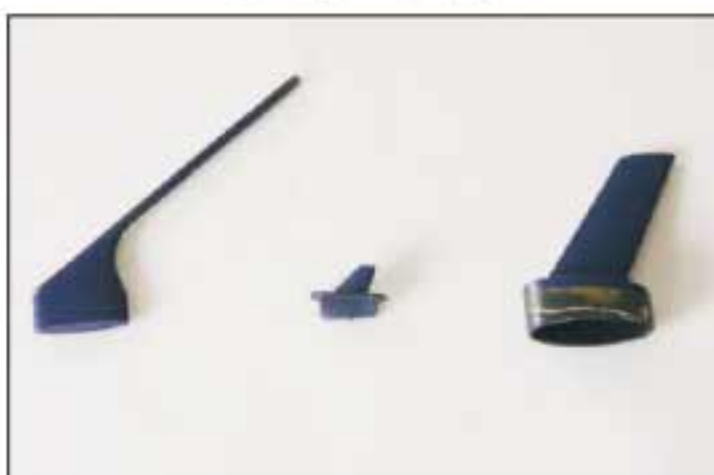

SI202-Blue



SI203-Blue SI204-Blue



SI205-Blue

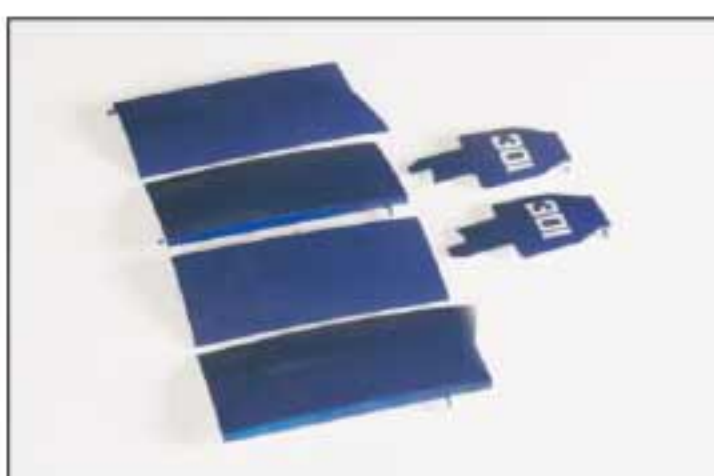

SI206-Blue



SI-207



SI208-Blue

Spare Parts List for Blue Scheme



SI209-Blue



SI-210



SI211-Blue



SI-301



SI-302



SI-303

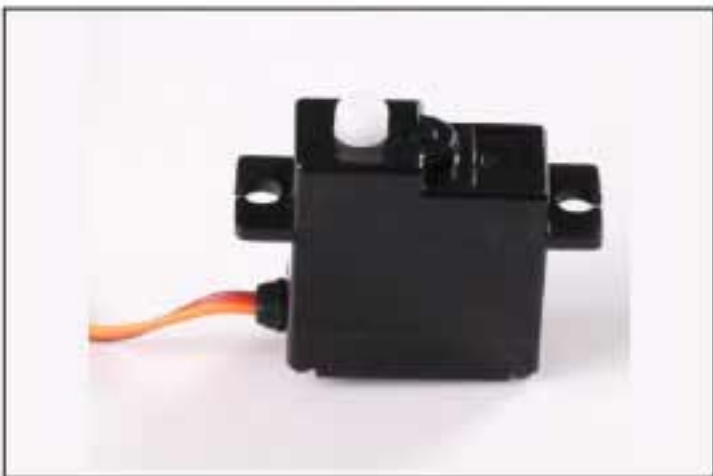

SI-304



SI-305



SI-306



SI-307



SI-308



SI-309



SI-310



SI-311



SI312-Blue



SI-313



SI-314

Trouble shooting

Problem	Possible Cause	Solution
Aircraft will not respond to the throttle but responds to other controls.	ESC is not armed. Throttle channel is reversed.	Lower throttle stick and throttle trim to lowest settings. Reverse throttle channel on transmitter.
Extra propeller noise or extra Vibration.	Damaged spinner, propeller, motor or motor mount. Loose propeller and spinner parts. Propeller installed backwards.	Replaced damaged parts. Tighten parts for propeller adapter, propeller and spinner.
Reduced flight time or aircraft underpowered.	Flight battery charge is low. Propeller installed backward. Flight battery damaged.	Remove and install propeller correctly. Completely recharge Flight battery. Remove and install propeller correctly. Replace flight battery and obey flight battery instructions.
Control surface does not move, or is slow to respond to control inputs.	Control surface, control horn, linkage or servo damage, Wire damaged or connections loose.	Replace or repair damaged parts and adjust controls. Do a check of connections for loose wiring.
Control reversed.	Channels need be reversed in the transmitter.	Do the Control Direction Test and adjust controls for aircraft and transmitter.
Motor loses power. Motor power pulses then motor loses power.	Damage to motor, or battery. Lose of power to aircraft. ESC uses default soft Low Voltage Cutoff(LVC).	Do a check of batteries, transmitter, receiver, ESC, motor and wiring for damage (replace as needed). Land aircraft immediately and Recharge flight battery.
LED on receiver flashes slowly.	Power lose to receiver.	Check connection from ESC to receiver. Check servos for damage. Check linkages for binding.

Battery Selection and Installation.

1. We recommend the 22.2V 3300mAh 25C Li-Po battery.
2. If using another battery, the battery must be at least a 22.2V 3300mAh 25C battery.
3. Your battery should be approximately the same capacity, dimension and weight as the 22.2V 3300mAh 25C Li-Po battery to fit in the fuselage without changing the center of gravity a large amount.

Flying Tips

Range Check Your Radio System

After final assembly, range check the radio system with the **FMS F4U**. Refer to your specific transmitter instruction manual for range test information .

Take off and landing tips

1. Take off using full power, as soon as you have taken off retract the landing gear.
2. Use the flaps to give a steeper landing approach, increase throttle slightly to offset the increased drag.
3. Ensure that you set a timer and land with plenty of battery power in reserve.
4. It's difficult to landing the plane perfect from the speedy flying state when the flaps keep in the contour.
5. Never exceed 3 minutes to fly with the maximum power others.
6. Never exceed the limited flying weight.

First Flight Preparation

1. Remove and inspect contents.
2. Charge flight battery.
3. Read this instruction manual thoroughly.
4. Fully assemble model.
5. Install the flight battery in the aircraft (once it has been fully charged).
6. Bind aircraft to your transmitter.
7. Make sure linkages move freely.
8. Make sure the rubber ring has been properly slide on the clevis.
9. Perform the Control Direction Test with the transmitter.
10. Adjust light controls and transmitter.
11. Perform a radio system Range Check.
12. Find a safe and open area.

Please read the following instructions and fully understand it.

1. Do not fly in strong wind or bad weather.
2. Never fly the model in crowded areas, where there are lots of people, automobiles on the road or power lines overhead . Also do not to fly around the airport. Please make yourself enough room for the flying and operating, as the plane can travel at high speed. Remember you are responsible for the safety of others.
3. Children under the age of 12 should have an adult guide. Never recommend for the children under the age of 14.
4. Never leave the charger in wet conditions.
5. The **F4U** is made from PA and polythene which are tinder. When it meets the heat, transfiguration can easily happen, so you must keep it away from heat.
6. Do not attempt to catch the **F4U** while flying, please do not touch the propeller.
7. Never leave this system unattended around children with battery in the unit, as injury may be caused due to children's turning on the transmitter or the plane.
8. During the preparation for the flight, please remember to turn on the transmitter before connecting the battery pack.
9. Close the throttle on the transmitter before connecting battery otherwise the motor may operate.

AMA

If you are not already a member of the AMA, please join, The AMA is the governing body of model aviation and membership provided liability insurance coverage, protects modelers' rights and interests and is required to fly at most R/C sites.

Academy of Model Aeronautics

5151 East Memorial Drive
Muncie, IN 47302-9252
Ph.(800)435-9262
Fax(765)741-0057

Or via the Internet at: <http://www.modelaircraft.org>



Academy of Model Aeronautics National Model Aircraft Safety Code Effective January 1, 2011

- A. GENERAL:** A model aircraft is a non-human-carrying aircraft capable of sustained flight in the atmosphere. It may not exceed limitations of this code and is intended exclusively for sport, recreation and/or competition.
All model flights must be conducted in accordance with this safety code and any additional rules specific to the flying site.
1. Model aircraft will not be flown:
 - (a) In a careless or reckless manner.
 - (b) At a location where model aircraft activities are prohibited.
 2. Model aircraft pilots will:
 - (a) Yield the right of way to all man carrying aircraft.
 - (b) See and avoid all aircraft and a spotter must be used when appropriate.
(AMA Document #540-D-See and Avoid Guidance.)
 - (c) Not fly higher than approximately 400 feet above ground level within three (3) miles of an airport, without notifying the airport operator.
 - (d) Not interfere with operations and traffic patterns at any airport, heliport or seaplane base except where there is a mixed use agreement.
 - (e) Ensure the aircraft is identified with the name and address or AMA number of the owner on the inside or affixed to the outside of the model aircraft.
(This does not apply to model aircraft flown indoors).
 - (f) Not operate aircraft with metal-blade propellers or with gaseous boosts except for helicopters operated under the provisions of AMA Document #555.
 - (g) Not operate model aircraft while under the influence of alcohol or while using any drug which could adversely affect the pilot's ability to safely control the model.
 - (h) Not operate model aircraft carrying pyrotechnic devices which explode or burn, or any device which propels a projectile or drops any object that creates a hazard to persons or property.

AMA

Exceptions:

- ◆ Free Flight fuses or devices that burn producing smoke and are securely attached to the model aircraft during flight.
 - ◆ Officially designated AMA Air Show Teams (AST) are authorized to use devices and practices as defined within the Team AMA Program Document (AMA Document #718).
3. Model aircraft will not be flown in AMA sanctioned events, air shows or model demonstrations unless:
 - (a) The aircraft, control system and pilot skills have successfully demonstrated all maneuvers intended or anticipated prior to the specific event.
 - (b) An inexperienced pilot is assisted by an experienced pilot.
 4. When and where required by rule, helmets must be properly worn and fastened. They must be OSHA, DOT, ANSI, SNELL or NOCSAE approved or comply with comparable standards.

B. RADIO CONTROL (RC)

1. All pilots shall avoid flying directly over unprotected people, vessels, vehicles or structures and shall avoid endangerment of life and property of others.
2. A successful radio equipment ground-range check in accordance with manufacturer's recommendations will be completed before the first flight of a new or repaired model aircraft.
3. RC model aircraft must use the radio-control frequencies currently allowed by the Federal Communications Commission (FCC). Only individuals properly licensed by the FCC are authorized to operate equipment on Amateur Band frequencies.
4. RC model aircraft will not operate within three (3) miles of any pre-existing flying site without a frequency-management agreement (AMA Documents #922-Testing for RF Interference; #923- Frequency Management Agreement)
5. With the exception of events flown under official AMA Competition Regulations, excluding takeoff and landing, no powered model may be flown outdoors closer than 25 feet to any individual, except for the pilot and the pilot's helper(s) located at the flight line.
6. Under no circumstances may a pilot or other person touch a model aircraft in flight while it is still under power, except to divert it from striking an individual. This does not apply to model aircraft flown indoors.
7. RC night flying requires a lighting system providing the pilot with a clear view of the model's attitude and orientation at all times.
8. The pilot of a RC model aircraft shall:
 - (a) Maintain control during the entire flight, maintaining visual contact without enhancement other than by corrective lenses prescribed for the pilot.
 - (b) Fly using the assistance of a camera or First-Person View (FPV) only in accordance with the procedures outlined in AMA Document #550.

C. FREE FLIGHT

1. Must be at least 100 feet downwind of spectators and automobile parking when the model aircraft is launched.
2. Launch area must be clear of all individuals except mechanics, officials, and other fliers.
3. An effective device will be used to extinguish any fuse on the model aircraft after the fuse has completed its function.



Email: info@fmsmodel.com
Http: // www.fmsmodel.com

MADE IN CHINA