

R6F

(FHSS)

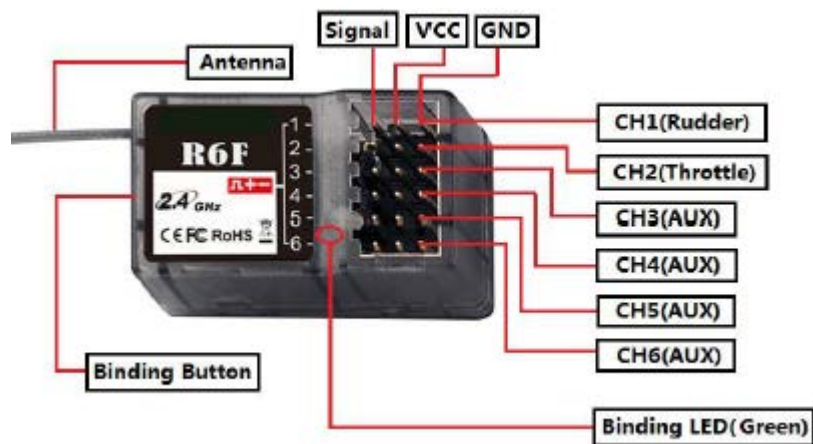

R6F, 2.4GHz 6 channels receiver, gyro integrated and HV servo supported. Compatible with Radiolink 6 channels pistol grip radio RC6GS, 4 channels pistol grip radio RC4GS, RC4G, RC3S and 8 channels transmitter T8FB.



How to Match Code With Transmitter:

1. Put the transmitter and the receiver close to each other within 50 centimeters.
2. Turn on the transmitter, then power on the R6F.
3. There is a black button on the R6F, press the binding button twice in two seconds and release, receiver light start blinking, after about blinking 8 times, match code success then receiver signal LED always on.

Specification

- 1) Frequency: 2.4GHz ISM band(2400MHz~2483.5MHz)
- 2) Size: 35*20*13mm
- 3) Channel: 6
- 4) Model: cars/boats
- 5) Modulation mode: GFSK
- 6) Spread spectrum: FHSS
- 7) 10 modes memory storage
- 8) Antenna length: 200mm
- 9) Control distance: more than 400 meters
- 10) LCD screen: 128*64 resolution, LCD back light
- 11) Power supply: 4.8~10.0V DC
- 12) RF power: <10dbm
- 13) Channel resolution: 4096
- 14) Work current: 30mA
- 15) Compatible with transmitters: RC6GS, RC4GS, RC4G, RC3S, T8FB, ATX6

Installment of receiver antenna :

1. The antenna must be kept as straight as possible. Otherwise it will reduce the effective range.
2. Large model aircraft may of some metal part interfering signal; in this case the antennas should be placed at both sides of the model. Then the best RF signal condition is obtained at any attitude.
3. The antennas must be kept away from conductive materials, such as metal and carbon by at least a half inch. The coaxial part of the antennas does not need to follow these guidelines, but do not bend it in a small radius.
4. Keep the antennas away from the motor, ESC, and other noise sources as much as possible.
5. Press and hold the Easy Link (ID SET) one second, now the receiver starts work.
6. After all of the above steps finished, the LED indicator will turn and keep in red/green.
7. The receiver can be packed by sponge or foam for shocking proof when it is installed to the model.

After all of the above steps finished, turn off the transmitter and then power it on, now the program functions to assure it under control of transmitter with a right connection.