

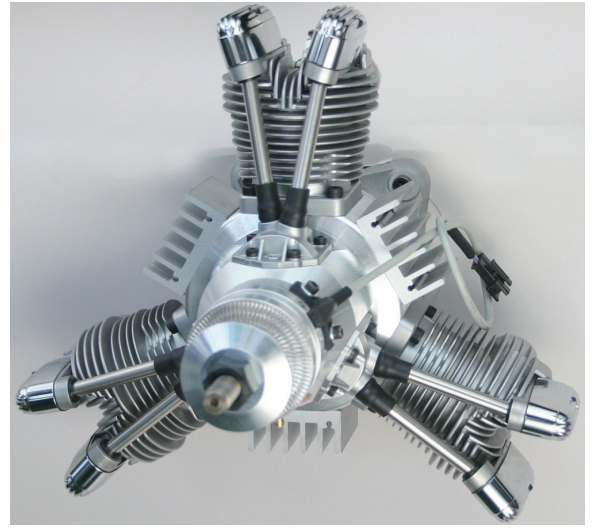

SAITO FG-84R3

4-Stroke Gasoline radial Engine Operating instructions

Thanks for buying SAITO FG-84R3 4-stroke gas-engine exclusively for model airplanes.
 In order to avoid misuse, please be sure to read well this instruction manual carefully. If there should be any deficiency, inconvenience, etc. concerning the manufacture, our company will repair them with responsibility. Any failure or trouble caused by unnecessary disassembly, modification, or other uses than those provided in the instruction manual is not subject to the warranty, however.
 Moreover, all responsibilities for the use of the engine, and other obligations and responsibilities based on laws, regulations, etc. are borne by the purchaser and the user, and SAITO SEISAKUSHO CO., LTD. is exempt from any responsibilities.



SAITO FG-84R3 is the gas-version of existing glow FA-450R3 with bore up. This new designed gas-engine is a figure of integration of many experiences on our radial engines and gas-engines. Additional designs concentrate on durability and high power brought it powerful and beautiful radial sound.

Notification about treatment of 4-stroke model gas-engine

- ⊙ Since valve timing is designed to get high power and high speed, the overlap range is relatively wide. So sometimes fuel get flown back from the carburetor. (It may spatter in the engine room.)
- ⊙ Since the oil for lubrication is mixed in the fuel, waste oil from the breather nipple is dirty. Depending on treatment of waste oil, it can be spattered on the plane.
- ⊙ Since lubrication is through breather, sometimes the oil oozes from each joint or commissure however it's no problem on performance.
- ⊙ Depending on the quality of the oil, sometimes there can be rust inside the crankcase. But it's no problem on performance as long as there are no abnormal noise or backlash.

Specifications

Bore	∅36.0mm x 3	Stroke	27.6mm x 3	Disp.	84.28cc
Weight	Body: 3,057g / Mufflers: 157g / Ignition system: 250g / Mount spacer: 64g (16gx4)				
Practical speed	Approx. 1,300-7,000rpm	Max on GND	Approx. 5,500-6,500rpm		
Propeller	D24" x P10" standard	Static thrust	Approx. 7~9kgf (Depend on prop)		
Fuel	Regular gasoline: Oil=20:1 (Volume ratio)		Applications	2st Gas-engine 60~70cc class	
Fuel consumption	Approx. 40cc/min (At full throttle 6,200rpm) *Fuel flow varies depends upon prop load. More fuel flow with larger load and less fuel flow with smaller load.				
Battery for ignition system	Voltage: 6-9V higher than 1,000mA is recommended				
Standard accessories	Engine mount set (Mount spacer)	4pcs	Aluminum prop washer (w/steel washer)	1set	
	Ignition system (w/ sensor)	1set	Limit gauge (0.1t) for tappet adjustment	1pc	
	Spark plug [NGK CM-6] (Attached to engine)	3pcs	Spanner for tappet adjusting lock nut	1pc	
	Muffler set (3 Flexible mufflers & Bracket)	1set	Hexagonal wrench set	1set	
	Carburetor adjustment bar	1pc	Plug wrench	1pc	
	Choke bar	1pc	Anti-loosening nut	1pc	

Outside dimensions

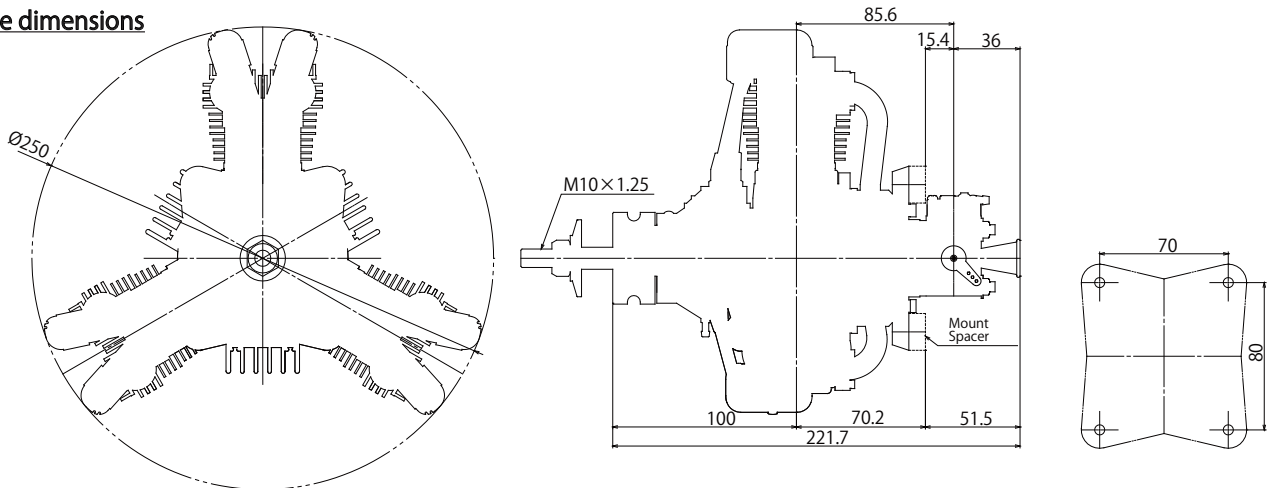

1. Propeller

Standard spec is Meizlik D24" x P10" which brings approx. 6200rpm. Depending on the airframe, please adopt the adequate size in the range of 5500~6500rpm from reliable products generally on the market. (Carbon prop is recommended)
Since a large-diameter prop is used, please maintain sufficient balance. Since an imbalanced prop is vibratory and dangerous with lowered performance, please maintain balance with a balancer. Moreover, a cracked prop is dangerous. Make sure to check any time and replace it with a new one if it's cracked.

*Tighten up the prop nut once in about every 10 flights. Especially a wooden prop tends to compressed so take care of its looseness.

2. Fuel

The fuel is mixture of commercial regular gasoline and reliable oil for 2-stroke. (Unleaded high-octane gasoline is not necessarily required for SAITO engine.)

[Example of oil]

- POWER LUBE (KLOTZ ORIGINAL TECHNIPLATE)
- KLOTZ GS RC model LUBE
- CASTROL POWER1 TTS Racing, etc.

For the mixture ratio, please be sure to use "gasoline : oil = 15~20 : 1" or richer by volume ratio. (ex. 1000ml of gasoline should be mixed with more than 50ml of oil).

Any damage caused by the fuel used, in which the oil ratio is lower than 20:1 ratio, is not warranted.

Since gasoline is dangerous material, be careful of its storage, use, and transport enough. (The evaporative emission and exhaust smoke of gasoline have a harmful effect on a human body. Also, if gasoline is leaked, there is danger of fire etc.) Please note that we take no responsibility for accidents, health damages, etc which occur during storage, use and transport of gasoline.

3. Fuel Filter and fuel pump

Since commercial gasoline has many impurities, please be sure to use a reliable filter for the admission port of the gasoline-proof fuel pump (Fig.3), and in the fuel tank as well (Fig.4). Without using a filter, the performance of the carburetor is not delivered, resulting in failures.

Using optional part "Filter with weight" is highly recommended.

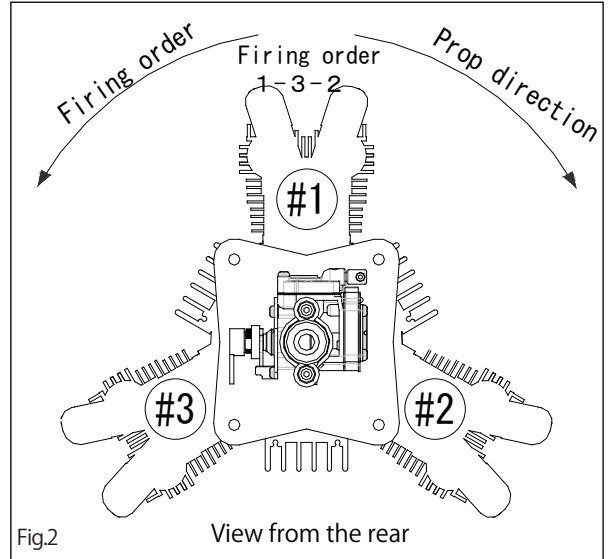

Fig.2

View from the rear

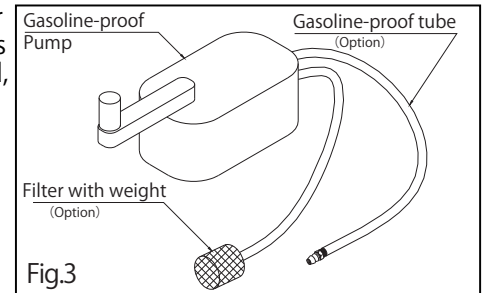

Fig.3

4. Fuel tank and piping

Use the gasoline proof tank which has adequate capacity (Approx. "Fuel consumption x Flight duration + 100~200cc). Please be sure to use a filter with weight. To avoid entrain any impurities to the carb, piping with "Fuel feeding pipe" and "Air inhalation pipe" (Fig.5) is recommended.

*Please be sure to use "gasoline-proof" products for the tank, lid rubber, piping, and tubing. Some of the products for glow fuel can't be used for gasoline.

*Please check carefully if there're any crack on the piping, tubing, connection, and tank. All of the connection parts should be bound by thin Nylon strap or wire to avoid fuel leakage or air induction to the fuel line. (If there are any leakages, the performance of the engine decreases dramatically.)

*The carburetor has a pump but its pumping pressure is not so strong. So place the tank close to the engine as much as possible. And set the fuel level slightly lower than the center of the carb.

*When provide "Air inhalation pipe" as Fig.5, arranging the tube above the fuel level is the effective way of fuel leakage prevention.

*The carburetor comes out from the back of the firewall. Sometimes fuel get flown back from carburetor and may spatter inside the firewall. For that case, make sure to cover the batteries, R/C equipments and all the foam members with gasoline-proof material.

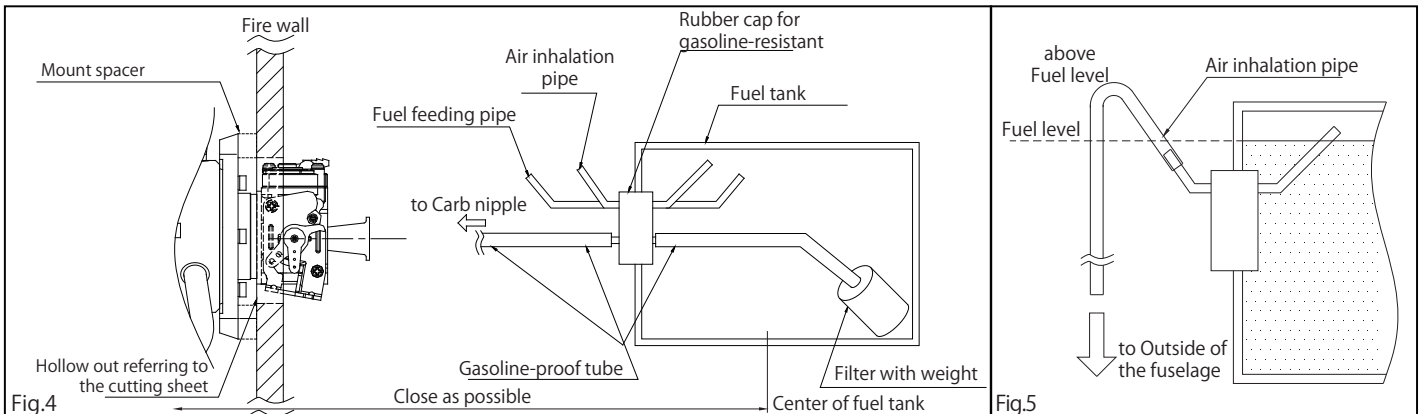

Fig.4

Fig.5

5. Ignition system

*Be careful of possibility of electrical shock as it generates high voltage.

*The unit includes a plastic clip to hold the connectors and spiral tube to protect each wire.

The ignition system is designed to match SAITO 4-stroke gas-engines with automatic advancing system.

However this ignition system is designed to be an anti-noise product, please isolate it completely from the receiver, servo, and battery to avoid a radio-interference trouble. Moreover, it is desirable to utilize a noise filter (line filter). Especially, each switch (for Ignition and for Receiver) should be isolated and set far from each ones.

Caution: A gas-engine generates a noise which has an adverse effect on RC adjustment. Please be sure to carry out a noise check each time while the engine is running before flight. Since a noise which occurs during flight may lead to a large-scale accident, please carry out a noise check without fail. As a simple method, after starting engine you can check by removing the antenna of the transmitter and operate it about 50m away from the airplane. If there is no malfunction, it is normal.

The function of each cord:

(1) Plug cord (meshed high tension cord)

As Fig.6 shows there are three cords available for three cylinders. Make sure to attach each number described on the main unit to the cylinder. (Refer to Fig.2 regarding cylinder number). When you put on the plug cap, insert deep into the plug to avoid coming off during flight. And then pull the plug cap to confirm that it won't come off.

(2) Sensor cord (Gray cord with exclusive connector)

Connect with the cord from the sensor attached to the engine.

(3) Battery cord (black/red cord)

Please use the fully charged battery that has adequate spec. (6-9V, more than 1000mA is recommended.). Between the battery and main unit, make sure to set an ignition switch whose capacity is higher than 3A.

(4) Tachometer cord (black/red/white cord)

Connect the digital tachometer (Option). Otherwise the connector is normally vacant.

6. Spark plug

NGK CM-6 spark plug is the standard equipment.

Dimensions are as follows;

Hexagon width: 14mm

Screw size : 10mm

Reach : 8.5mm

Spark-gap : 0.7-0.8mm

For replacement, please replace with a reliable product as NGK CM-6.

Since SAITO 4-stroke engine uses mixed gasoline, please decide the numbers of flights by yourself to clean the spark plug. Please replace, when it is degraded. (Consider the plug as consumable.)

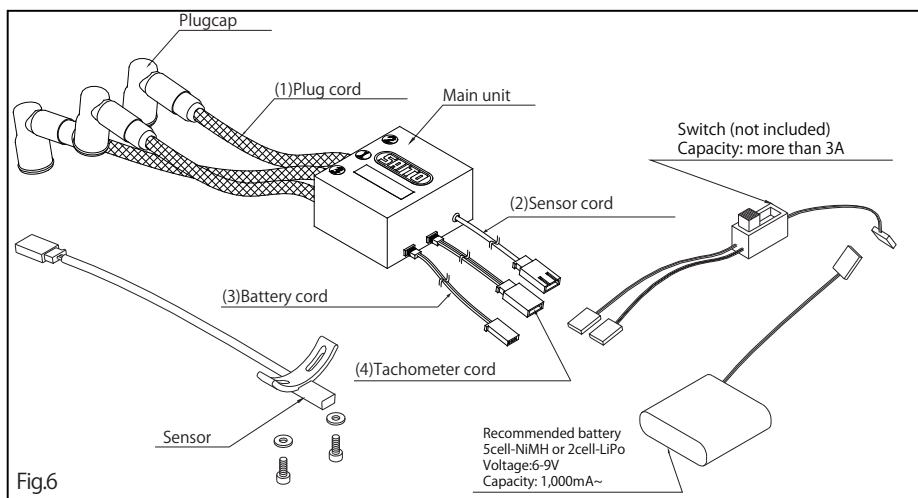

7. Carburetor

Equipped with a suitable carburetor by technical cooperation with "Walbro" that provides highly reliable carburetors for other gas-engines. Because of its structure, in some case performing "Air purging" just before flight is recommended. Regarding this please refer to the attached document.

Note: To avoid entraining air lock in the carb, it is better to leave fuel in the carb after running. But in such way of storing, gasoline accelerate degradation of rubber parts such as diaphragm.
The carburetor for a gas-engine is elaborate and delicate. Please never disassemble it. If it's out of condition, please consult the shop you bought from.

Method of choking (For manual start only)

(1) As shown in Fig.7, pass the choke bar (with M3.5 thread on its tip) through the hole on the cowling. Then turn the bar to insert into the M3.5 internal thread at the center of the throttle lever.

(2) Pull the choke bar and fix it by using a clip or clamp as shown in Fig.7 so that it may not go back to the previous position.

(3) Grasp the prop by hand and turn it to the forward direction (CCW) for several times, until the carburetor generates hissing-like sounds.

(4) After hearing this sound for about 5 times, quickly flick the prop by cranking it some 10 times. Then choking is completed.

(5) Remove the choke bar.

(6) Power on the ignition system and open the throttle valve about 1/4 from the full close position by using the throttle stick. (Starting with excessively opened throttle is dangerous since the airplane jumps forward.)

(7) Flick the prop quickly and engine will start. If the engine doesn't start, repeat the choking procedure (1) to (6).

*After starting, run the engine for 10 to 20 sec to warm up.

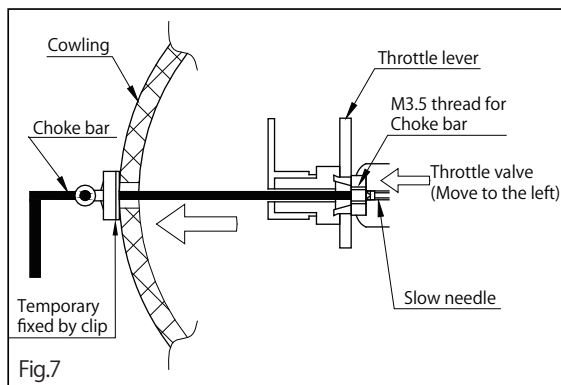

8. Engine mounting, muffler attachment, and breather waste disposal

FG-84R3 can be installed with mount spacers. As the carb comes out from back of the firewall, hollow out the firewall as possible as minimum referring to the cutting sheet included. Make the firewall robust enough because this part has to endure vibration and torque caused by prop rotation. Especially with a low load prop, engine tend to generate large vibration that is very dangerous.

It is preferable to apply some adhesives (such as screw lock) on the tip of each cap screw to avoid looseness when you install the engine.

To ensure that cooling wind passes through the engine, the cowling should be devised. Also make the air flow outlet larger than the inlet.

Building some baffles inside the cowling to flow the cool air through the surface of the engine effectively that is highly recommended. Insufficient cooling may cause engine trouble such as overheat, percolation, or muffler looseness.

The mufflers should be securely inserted deeply into the cylinder and tightened up using spanners. (Adhesives, such as a screw lock agent, are effective against looseness and leakage.) Make sure to fix the outlet of the flexible mufflers outside of the cowling using the bracket included. (Regarding muffler installation, please refer to the attached document.)

For breather treatment, there is also a method in which the aluminum pipe, etc. are fixed at the muffler outlet to diffuse the hot air together with exhaust gas into the air. (Breather may function by simply ejecting the tube from the engine).

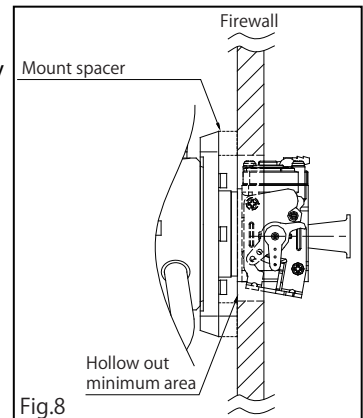

Fig.8

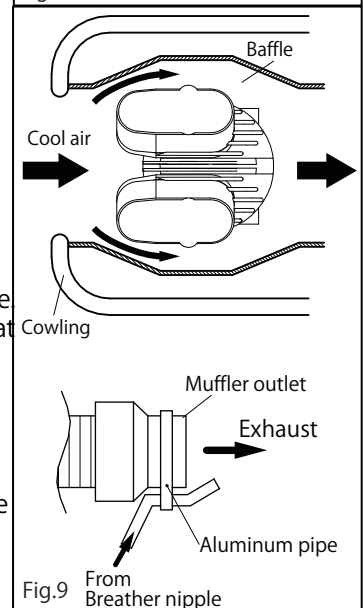

Fig.9

9. Preparation for engine start (assuming break-in)

- (1) Mount the engine on a robust and parallelized test bench or on the fuselage. (Either way, the engine should be fixed and immobile.)
- (2) Check whether the throttle valve becomes fully closed and opened certainly.
- (3) Check whether each code of the ignition system is connected certainly.
- (4) Use about 1000cc tank for the test bench, or a tank which has appropriate capacity for the fuselage.
- (5) For piping, only connecting the carburetor with the tank is needed. (Make sure there's no leakage at all the connections.) In order to check discharge of the breather, attach a heat-proof and gasoline-proof transparent tube to the breather nipple.
- (6) For fuel, prepare a mixed gasoline with a volume ratio of "gasoline : oil" = "15~20 : 1".
- (7) Prepare a well balanced 24"x 10" carbon-made prop (Mejzlik is recommended).
*Prop attaching position
Since SAITO 4-stroke gas-engine can be manually started in forward direction of the rotation, fix the prop in the position which facilitates vigorous cranking.
- (8) When starting with an electric starter, also attach a spinner. (This way of start is recommended for safety.)
- (9) As it is difficult to judge clearly the peak condition of 4-stroke engines, prepare a tachometer to prevent over-throttling or overheat. You can also use digital tachometer (Option).
- (10) Prepare a fuel pump for gasoline. (Be sure to attach a filter to the intake port. It is available as an option.)

Caution: If there's anyone stand in front of the engine, be sure to have them move behind the airplane before starting the engine. Also keep in mind that the exhaust smoke is harmful for health. Keep away one of your arm holding the airplane away from the prop. Once the engine starts, move behind the airplane. Make needle adjustment or other control from rear. If the airplane cannot be fixed, ask your assistant to hold the airplane for safety.

10. Method of starting the engine

The following is the procedure with the engine mounted on the airplane. Fill up the tank with fuel. (Be sure to turn off the switch of the ignition system until just before trying to start up the engine.)

(A) Starting method with a starter (Recommended)

- (1) After confirm that the throttle stick is located at the full-close position, turn on the transmitter switch. Then turn on the receiver switch to check throttle valve and other operation. After that, fully close the throttle valve.
- (2) Power on the ignition system.
- (3) Open the throttle valve about 1/4 from the full close position by using the throttle stick. (Starting with excessively opened throttle is dangerous since the airplane jumps forward.)
- (4) Apply the starter to the prop and activate for about 5 seconds to start the engine.

(B) Manual starting method (For safety, wear gloves and use a safety stick)

- (1) Same as (1) noted above. (The throttle valve must be fully closed. Otherwise, the fuel cannot be manually introduced.)
- (2) Make sure to turn off the ignition switch.
- (3) Following Chapter 7, perform choking method. ("Choking"- "Ignition ON"- "Throttle 1/4 open"- "Flick")

11. Break-in (Referring Fig.10, check in advance where the Main needle and Slow needle are placed.)

As Break-in is an important procedure to pull out the maximum performance of the engine, it must be cautiously done. The purpose of break-in is initial lubrication and adjusting of the mobile parts under the condition with rich fuel mixture. Never make the fuel mixture lean. Lean fuel mixture could cause seizure even during idling or low speed running. There's no need to adjust the slow needle at this step as it's already set adequately, so you will adjust only the main needle during break-in.

Procedure;

- (1) After filling up the fuel tank, start the engine as described in the above Chapter 10 and run it for 10 sec in low speed.
- (2) Open the main needle 2 turns from that state and use the throttle stick to fully open the throttle valve. If rich air-fuel mixture can't be obtained, open the main needle additionally. Then continue running for more than 1 tank. During this initial operation, contact of each part inside the engine will be matched. So make the fuel mixture rich as much as the engine doesn't stop. Do not care about running smoothness at this step.

- (3) Refill the tank and run the engine with the main needle to achieve peak and less speed (richer) alternately about 5 times. And then maintain the peak condition long gradually. When it gets stable, then operate the throttle stick to vary slow speed to high speed several times to check the response. After that run it for 1 tank keeping high speed.
- (4) When it comes to run smoothly at peak, break-in on the ground is completed. Then perform tappet adjusting referring to Chapter 13 and adjust the carburetor referring to Chapter 12. After that, fly it for about 20 times in rich condition to finish break-in in the air.

Also after break-in, please run the engine in rich condition as long as it doesn't affect to the flight.

Note: During early stage of flights, take the height high enough to land safely in case the engine stop in the air suddenly. It will reduce the risk of crash or landing accident.

12. Adjustment of carburetor

Before adjustment, please set both needles as the standard values.

In principle, the carburetor should first achieve peak by adjusting the main needle. Then performing idling with the throttle valve and the slow needle. (Unless the peak is certainly achieved, idle adjustment will be difficult and not stabilized.)

*The slow needle is set as to keep around 1,300~1,500rpm at idling at factory default.

- (1) After filling up the fuel tank, start the engine as described in Chapter 10 and run it for 1 minutes in rich condition. Then fully open the throttle valve with the throttle stick.
- (2) By turning the main needle with the adjustment bar observing tachometer and exhaust sound, achieve peak carefully.

Caution: Too much throttling the main needle is very dangerous because it might cause knocking and the prop nut might be came off. Once you notice abnormal vibration or sound during throttling the main needle, just return to open the needle immediately.

- (3) Next, close the throttle valve until the engine runs stably with an idling rotation around 1,300rpm by adjusting the slow needle with the adjustment bar carefully. (During flight, it's rather stable with slightly high adjusted at idling.)

*The best richness of the air-fuel mixture at slow speed is depend on the flight style. Generally, Scale flight requires stability in low speed so slightly lean condition is preferable. On the other hand Acrobatic flight requires quick response from low through high, so slightly rich condition is preferable.

- (4) Once the idling is set, get the throttle valve fully opened gradually. If the revolution becomes slow or goes up suddenly, adjust the slow needle carefully until rpm raises linearly from idling to peak by fine-tuning.
- (5) After adjustment of (4) is completed, perform the process from idling to peak quickly. If revolution gets delayed to achieve peak even if the throttle valve is fully opened, fine-tune the main needle and perform the same process. Repeat this fine-tune and response check carefully until the response improves.

*Tip for adjustment of the slow needle is to make lean as possible as the engine don't get stole when open the throttle valve quickly. At the same time, since a gas-engine has narrow range of air-fuel ratio, adjustment of the needles is stricter than a glow-engine. And both needles are interfered slightly from each other so confirm the balance of peak and response after adjustment.

*To keep the engine life longer, adjust the fuel mixture as rich as possible in the range it doesn't affect to the running. Carb adjustment is affected by many factors such as prop, flight style, atmosphere (humidity, temperature, ...) ,oil, plug, fuel, and so on. Please keep trying to find the best condition to match your plane.

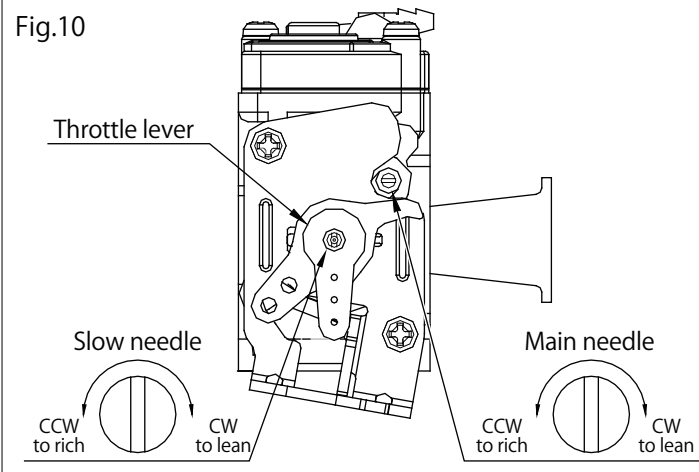
<p>Fig.10</p> 	<p style="text-align: center;"><u>Standard value for the needles</u></p> <p>In case such like follows, reset the needle to the Standard value (SDV).</p> <ul style="list-style-type: none"> • After break-in • When adjustment can't be done correctly. • When by failure, turning the needle too much. <p>To set SDV, first fully close the needle. (DO NOT close too tightly. The needles can be torn easily).</p> <p>After that open the needle to SDV as follows. Throttle valve should be fully closed during setting to SDV.</p> <p><u>SDV for Main needle:</u> 2 turns open from full close</p> <p><u>SDV for Slow needle:</u> 4.5 turns open from full close</p>
--	--

13. Normal operation, maintenance, and additional information

- (1) Just after start up the engine, perform warm up running in rich condition for about 1 minute, and just before stop run it at idling for 1 minute to cool down as well. When stop the engine after the final flight of the day, be sure to stop by cutting the fuel to remove fuel from the carburetor. And remove the fuel from the tank and reserve it with special care.

*When start the engine first after stop it by fuel cut, performing air purging is recommended. (Refer to the attached document.)

- (2) Charge the battery for the ignition system and RC device fully. (Since the ignition system generates high tension, be careful of electrical shock.)
- (3) Lubrication for piston, connecting rod, bearing or cam gear is a blow-by lubrication in which the oil in the fuel goes into the crankcase from the clearance between the cylinder and piston. Therefore the engine life is affected by the property of the fuel oil. Please use reliable oil.
- (4) Since over closing the main needle causes overheating, adjust a little more rich than peak. Over closing leads to knocking or overheat and has an adverse effect on the connecting rod and cam gear. Where the airplane achieves peak completely at the attitude of ascent should be a proper peak of the engine during flight.
- (5) When connecting the exhaust pipe to the cylinder or attaching the prop nut, apply thin coat of silicon rubber (not excessively) or adhesive on the thread section before tightening. This prevents leakage or loosening.

- (6) Occasionally tighten the prop nut and exhaust nut.
- (7) Take an extreme care for safety when operating the engine or flying the model airplane not to bother others.
- (8) An engine for a model airplane is not a toy. Handle it with an extreme care.
- (9) After completing ground break-in or operating the engine for 1 hour, adjust tappet gaps (valve clearances) by following procedure to compensate initial wearing, while the engine is cold.

#1 cylinder should be adjusted first, next #3, finally #2 cylinder should follow in order by the same procedure.

- (a) Remove the plug and rocker covers from the #1 cylinder.
- (b) Turn the prop slowly forward by hand until the rocker arm of intake stops. Further turn the prop to bring the piston to the TDC (Top Dead Center) of compression stroke.
- (c) Use the attached wrench and hexagonal wrench to adjust the gaps indefinitely close to zero within the range compression exists. If the gap is lower than 0, the valve has to be opened at all phases so the compression doesn't occur (then, loosen the screw to reset).
After adjustment, put on the spark plug and turn the prop forward to check if the compression is enough.
- (d) Checking the gap, securely tighten (but not excessively) the lock nut.
- (e) Do the same adjustment for #3 cylinder.
- (f) Finally do the same adjustment for #2 cylinder.

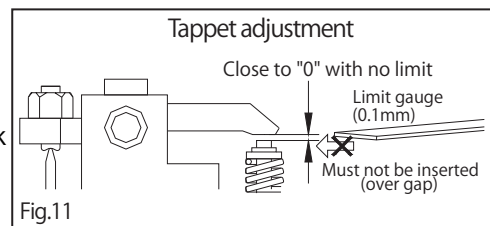

* In the case of the engines for vehicle, small gap is given to tappets to absorb valve elongation. However for SAITO engines, gap becomes larger during operations due to thermal expansion of the cylinder (made of aluminum). Therefore set the gap indefinitely close to zero when the engine is cold.

Note: Occasionally check tappet gap by those procedure. When the attached gauge (limit gauge, $t=0.1\text{mm}$) comes to be inserted, gap has been enlarged beyond the allowable limit. Make an adjustment to lessen the gap. Tappet gap is one of the most important factors in the maintenance of 4-stroke engines. Operating the engine with the tappet gap enlarged excessively will cause poor performance or troubles.

- (10) Since the fuel contains more than 5% of oil, sometimes the exhaust valve gets dull by carbon or sludge especially in cold atmosphere. Then turn off the ignition switch and rotate the prop by electric starter. After dilute the oil content by this way, remove the fuel from inside the carb and the engine. It helps the valve to move smoothly.
Or, remove the rocker cover and applying some anti-rust spray to the exhaust valve is effective as well.
- (11) Please notice that our guarantee will not cover any breakage or trouble on the engine caused by user's disassembling or modification.
- (12) Notes for purchasing parts:
Please give orders to the shop you purchased from with "Engine model", "Part No. or part name", and "Quantity".

Optional parts

- Filter with weight [36-154]
- Spark plug CM-6 [36-120]
- Cooling cover (1pair) [120S-166]
- Digital tachometer [17-168]
- Neoprene tube for gasoline(1m) [36-155]
- Aluminum spinner nut [57T-30]
- Tappet adjusting kit [120S-161]

All specifications and models are subject to change without notice.



<http://www.saito-mfg.com>

SAITO SEISAKUSHO, CO., LTD.

22-7, 3-chome, Tokagi, Ichikawa-shi, Chiba prefecture 272-0024, Japan

Phone: 047-378-2459 FAX: 047-378-4155

SAITO FG-84R3 Parts List(1/2)

No.	Item	Qty
01	Cylinder	3
06	Piston	3
07	Piston pin	3
08	Piston pin retainer	6
09	Piston ring	3
10	Master rod	1
11	Link rod	2
12	Link pin & Retainer & Washer 12-1,-2,-3	2ea.
14	Cylinder screw set 14-1,-2,-3,-4	1 set
15	Crankcase	1
17	Rear cover A	1
18	Rear cover B	1
19	Breather nipple	1
20	Front ball bearing	1
22	Rear ball bearing	1
23	Crank shaft	1
27	Taper collet & Drive flange 27-1,-2	1set
28	Prop washer & Nut 28-1,-2,-3	1set
31	Crankcase screw set 31-1,-2,-3,-4,-5,-6,-7	1set
32	Engine gasket set 32-1,-2,-3-1,-3-2,-4,-5,-8,-9	1set
33	Cam gear housing	3
35	Cam gear	3
36	Cam gear shaft	3
37	Steel washer set 37-1,-2	1set
38	Tappet	6
39	Push rod	6
40	Push rod cover & Rubber seal 40-1,-2,-3	1set
41	Rocker arm	6
42	Rocker arm screw & Nut 42-1,-2	1set
43	Rocker arm pin	6
44	Rocker arm bracket (left)	3
45	Rocker arm bracket (right)	3
46	Valve set (In & Ex)	6
47	Valve spring & Keeper & Retainer 47-1,-2,48	1set

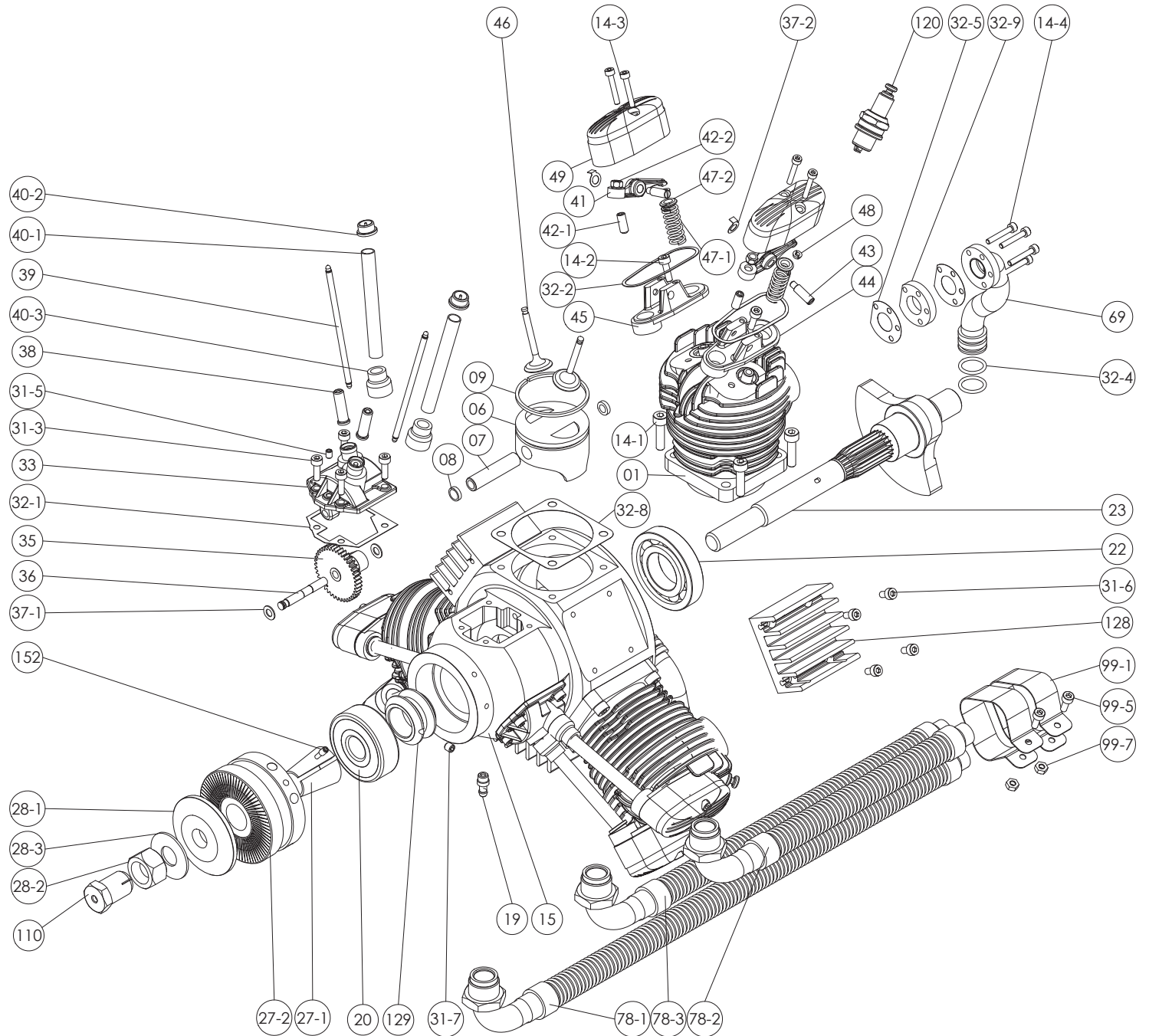

SAITO FG-84R3 Parts List(2/2)

No.	Item	Qty
48	Valve retainer (Cotter)	6
49	Rocker arm cover	6
69	Intake pipe	3
78	Flexible exhaust pipe	3
	78-1,-2,-3	
82-1	Carburetor complete	1set
	82-1-1,-1-2,-1-3,-1-4,-1-5,-1-6 -1-7,-1-8,-1-9,88,93	
88	Throttle lever	1
95	Engine mount set	1 set
	95-1,-2,-3,-4	
99	Muffler bracket set	2set
	99-1,-5,-7	
110	Anti loosening nut	1
120	Spark plug (NGK CM-6)	3
121	Master rod plug	1
128	Heat sink	3
129	Lubrication adopter	1
152	Screw pin (For drive flange setting)	1
153	Electronic ignition system	1set
	153-1,-2,-3,-4	

